

SCREENGUARD™

AUTOMATIC HORIZONTAL SCREEN FILTER

INSTALLATION AND USER MANUAL

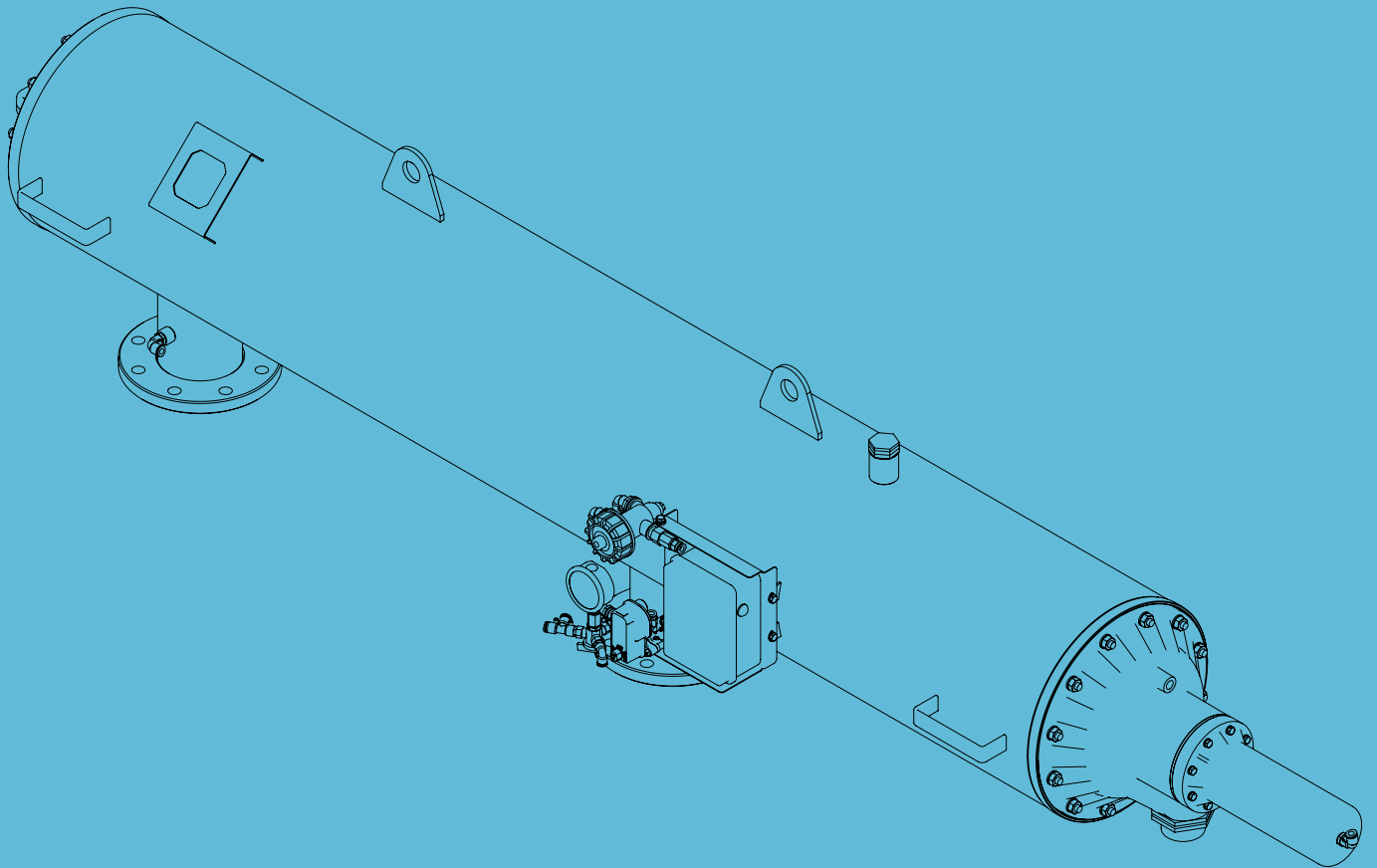

© COPYRIGHT 2020, NETAFIM™

NO PARTS OF THIS PUBLICATION MAY BE REPRODUCED, STORED IN AN AUTOMATED DATA FILE OR MADE PUBLIC IN ANY FORM OR BY ANY MEANS, WHETHER ELECTRONIC, MECHANICAL, BY PHOTOCOPYING, RECORDING OR IN ANY OTHER MANNER WITHOUT PRIOR WRITTEN PERMISSION OF THE PUBLISHER.

ALTHOUGH NETAFIM™ TAKES THE GREATEST POSSIBLE CARE IN DESIGNING AND PRODUCING BOTH ITS PRODUCTS AND THE ASSOCIATED DOCUMENTATION, THEY MAY STILL INCLUDE FAULTS.

NETAFIM™ WILL NOT ACCEPT RESPONSIBILITY FOR DAMAGE RESULTING FROM THE USE OF NETAFIM'S PRODUCTS OR THE USE OF THIS MANUAL.

NETAFIM™ RESERVES THE RIGHT TO MAKE CHANGES AND IMPROVEMENTS TO ITS PRODUCTS AND/OR THE ASSOCIATED DOCUMENTATION WITHOUT PRIOR NOTICE.



FOREIGN LANGUAGES

In the event that you are reading this manual in a language other than the English language, you acknowledge and agree that the English language version shall prevail in case of inconsistency or contradiction in interpretation or translation.

CONTENTS

Introduction

Aim of this manual	4
General instructions	4
Contact for support	4
Safety instructions	5

Description

Filter selection	6
Components and structure	6
Filter operation - general description	7
Dimensions	8
Connection diameter	9
Weights	9
Head loss	9
SG1 Smart Bluetooth flush controller	10
Control tubes	12

Installation

Pre-installation preparations	13
Tools required for installation	13
Unpacking and placement	13
Hydraulic installation	14
Bluetooth flush controller activation	15
External power supply (optional)	17

Initial operation

Preparations	18
First operation	18
Application operation	19

Maintenance

Safety instructions	25
Tools required for maintenance	25
Maintenance schedule	25
Screen assembly cleaning	26
Replacing the batteries	27
Paint retouching on the filter body	28
Algae growth control	28
Winterization	29

Troubleshooting

General malfunctions	30
Filter body opening - strainer side, and screen assembly extraction	31
Filter body opening - piston side	31
Flushing-assembly release	32
Flushing-nozzle replacement	32
Piston-gasket replacement	33
Piston seal replacement	33
Turbine brass bearing replacement	33
Centering ring w/bearing replacement	34
Control tube fast connector	34
Hydraulic relay replacement	34
Aquative solenoid replacement	35
PD sensor unit replacement	36

Replacement parts

Filters	38
Spare parts	39

Warranty

47

INTRODUCTION

Aim of this manual

This document is the user-manual of the Netafim™ ScreenGuard™ horizontal hydraulically controlled automatic screen filter series. It describes the installation, operation, maintenance and troubleshooting procedures of the filters.

General

Netafim™ congratulates you on purchasing the ScreenGuard™ self-cleaning filter. This filter is part of the wide family of filters produced and supplied by Netafim™ for agriculture, municipal water and sewage systems, and all types of industrial applications. All products manufactured by Netafim™ are easy to install, use and service and don't require special skills to operate them.

The ScreenGuard™ self-cleaning filter enables high quality filtration from various types of fluid sources such as sewage, reservoirs, rivers, lakes, and wells.

Contact for support

This manual offers a full explanation of the the installation, operation, maintenance and troubleshooting procedures of the ScreenGuard™ horizontal filter. However, in any case you need additional support, contact your Netafim™ local representative.

SAFETY

Safety instructions

General

- Carefully read the installation and operation instructions prior to installation or handling of the filter.
- While working with the filter all conventional safety instructions should be observed in order to avoid danger to the workers, the public or to property in the vicinity.



WARNING

Fully release the pressure in the filter before performing installation or maintenance operations involving opening the filter. Check the pressure gauge to be sure it is at 0 before proceeding.



WARNING

The filter may start a flushing cycle automatically at any time, without any prior indication.

- No changes or modifications to the equipment are permitted without written consent provided by the manufacturer or by its representative, on the manufacturer's behalf.
- Work only with proper and standard tools
(see [Tools required for installation](#), page 13; and [Tools required for maintenance](#), page 25).
- Use only original parts supplied/approved by Netafim™.

Operation, Control and Maintenance

- Loosening or unscrewing bolts should be done only after the pressure in the filter has been released.
- Avoid splashing and water leakage in order to reduce danger of slipping, electrical danger or damage to the equipment caused by moisture.
- Always open and close valves gradually to prevent water-hammer.
- Remove grease and fat material residues to avoid slipping.
- Manual cleaning of filter assembly using high water pressure should be performed in accordance with the cleaning system instructions and without endangering the operator or his working area.
- When using acid or other chemical agents for the maintenance of the irrigation system or for the cleaning of filter assembly, it should be performed in accordance with the relevant material safety instructions and without endangering the operator or his working area.

Use of Lifting Equipment

- While using lifting equipment, make sure that the filter or the lifted part is strapped securely and in a safe manner.
- Avoid working below lifted equipment.
- Wear a safety helmet while using lifting equipment.
- Lift the filter by the lifting anchors using hoisting straps in order to avoid damage to the filter's coating.
- Carry the filter by the carrying handles or by the metal body.
- The filter should not be carried by the filter caps, piston and piston chamber.

DESCRIPTION

Automatic horizontal screen filter selection

Netafim™ offers a selection of ScreenGuard™ automatic, horizontal screen filters to fit any filtration requirement:

Model	Description	Filtration area (cm ²)	Max. Operating pressure (bar/PSI)	Max. recommended flow rate (m ³ /h)	Min. backflush pressure (bar/PSI)	Backflush flow rate (m ³ /h)
SG H 4"	4" flanged	5,300	10/150	80	2/30	24
SG H 4" S	4" Super, flanged	7,900	10/150	100	2/30	36
SG H 6"	6" flanged	5,300	10/150	120	2/30	24
SG H 6" S	6" Super, flanged	7,900	10/150	150	2/30	36
SG H 8"	8" flanged	7,900	10/150	250	2/30	36
SG H 10"	10" flanged	7,900	10/150	300	2/30	36
SG H 210	System, 2 units, 10" flanged	15,800	10/150	500	2/30	36
SG H 312	System, 3 units, 12" flanged	23,700	10/150	750	2/30	36
SG H 414	System, 4 units, 14" flanged	31,600	10/150	1000	2/30	36



NOTE

- All horizontal filter models are available with BSTD, ANSI, ISO10 or ISO16 flanges.
- All filter models are available with 100, 130 or 200 micron (150, 115 or 80 mesh) filtration grade. (Other filtration grades are available upon request).

Components and structure

A ScreenGuard™ automatic horizontal screen filter is comprised of the following components:

- | | | |
|---------------------------------------|---------------------------------|--------------------|
| 1. Inlet | 6. Fine screen assembly | 11. Suction nozzle |
| 2. Outlet | 7. Strainer | 12. Pressure gauge |
| 3. Hydraulic piston | 8. Flush controller | 13. Drain port |
| 4. Hydraulic flushing turbine chamber | 9. Aquative operator (solenoid) | 14. Flushing valve |
| 5. Hydraulic flushing turbine | 10. Suction assembly | |

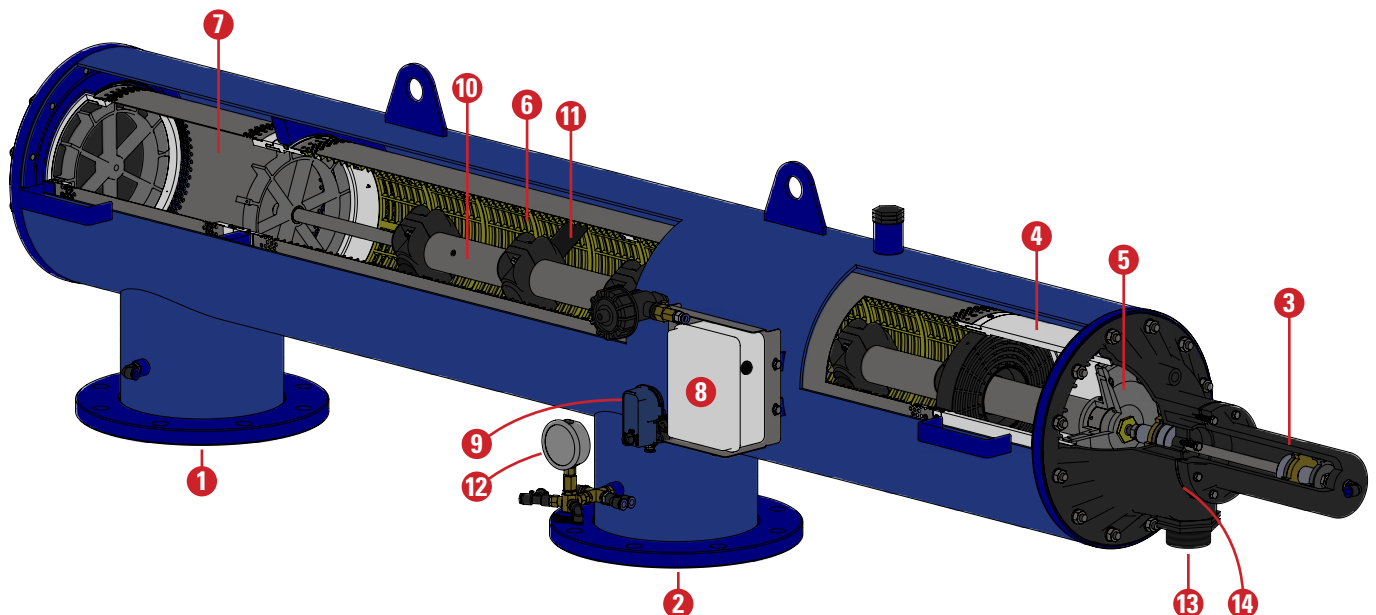

DESCRIPTION

Filter Operation - General Description

The Filtration Process

Water enters the filter through the inlet [1] and passes through the strainer [7] from the outside in. The strainer is designed to protect the cleaning mechanism from large dirt particles (The strainer is not cleaned automatically).

The water then flows through the screen filter [6] from the inside out to the outlet [2]. The entrapped particles form a "filtration cake" which accumulates on the screen inner surface. Over time the "cake" build-up increases the pressure differential across the screen, and at a pre-set value (0.5 bar; 7 PSI) the automatic self-cleaning cycle begins.

The Self-Cleaning Process

The self-cleaning process utilizes the backflush technique to effectively remove the dirt particles from the screen. The automatic flushing cycle takes 10-30 seconds and does not interrupt the supply of process water.

As water flows from the inlet through the strainer and screen to the outlet, at a pre-set pressure differential (0.5 bar; 7 PSI) the flush controller [8] activates the hydraulic piston [3] and opens the flushing valve [14].

The pressure in the hydraulic flushing turbine [5] chamber drops, creating suction at the flushing nozzle [11] tips. The water and particles passing through the hydraulic flushing turbine cause the suction assembly [10] to rotate, while the hydraulic piston [3] moves the suction assembly in an axial motion to the opposite end of the filter. The combination of rotational and axial motion of the suction assembly ensures that the suction nozzles sweep the entire inner surface of the screen.

When the first backflush stroke is completed, the flushing valve [14] closes, and after a very short interval the second backflush stroke is hydraulically triggered and the flushing valve reopens. The suction assembly [10] rotates, moving with the piston in the opposite direction and returning to its original position.

The ScreenGuard™ screen filter series are hydraulically operated units. No external power source is required. This type of control enables operation at remote installation sites.

DESCRIPTION

Dimensions

External dimensions and inlet and outlet locations [mm]:

Horizontal filters

Front view

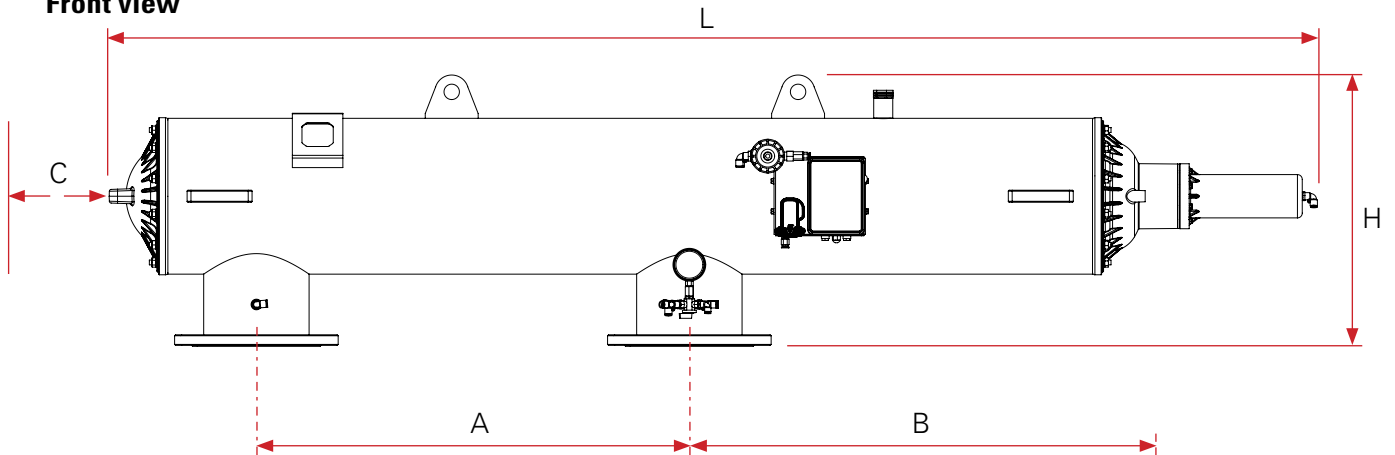

Bottom view

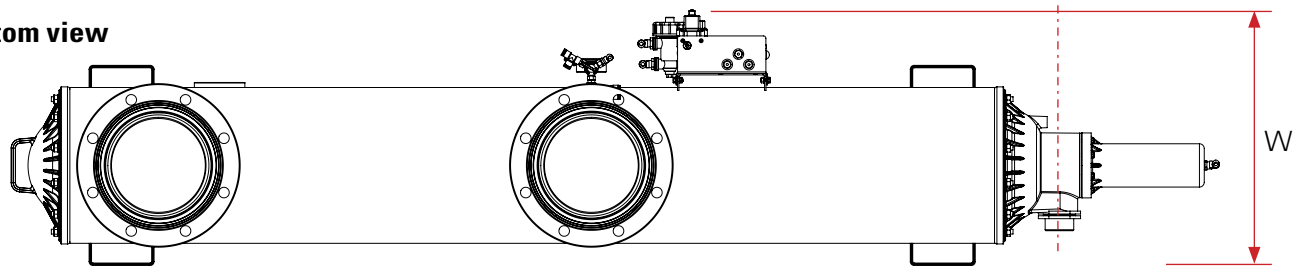

Model	External dimensions			Inlet and outlet location		Clearance for maintenance [C]
	Length [L]	Height [H]	Width [W]	Inlet to outlet [A] (Center to center)	Outlet to drain [B] (Center to center)	
SG H 4" F	2082	515	480	900	545	1500
SG H 4" SF	2512	565	530		973	2000
SG H 6" F	2082	515	480		545	1500
SG H 6" SF	2512	565	530		973	2000
SG H 8" F	2512	565	530		973	2000
SG H 10" F	2512	565	530		973	2000

Box dimensions

Model	Length [L]	Height [H]	Width [W]
SG H 4" F	2,220	570	710
SG H 4" SF	2,620		760
SG H 6" F	2,220		710
SG H 6" SF	2,620		760
SG H 8" F	2,620		760
SG H 10" F	2,620		760

Model	
SG H 210 F	Supplied in multiple separate boxes
SG H 312 F	
SG H 414 F	

DESCRIPTION

Connection diameter

Model	Inlet/outlet connection diameter	Backflush connection diameter
SG H 4" F	4"	50mm
SG H 4" SF	4"	
SG H 6" F	6"	
SG H 6" SF	6"	
SG H 8" F	8"	
SG H 10" F	10"	
SG H 210 F	10"	
SG H 312 F	12"	
SG H 414 F	14"	

Weights

Model	Weight (kg)	
	Net	Packed
SG H 4" F	90	118
SG H 4" SF	124	156
SG H 6" F	92	120
SG H 6" SF	131	163
SG H 8" F	137	169
SG H 10" F	143	175
SG H 210 F	Supplied in multiple separate boxes	
SG H 312 F		
SG H 414 F		

The weights in the tables above are order of magnitude only - final data are issued with the product order.

Head loss (clean filter)

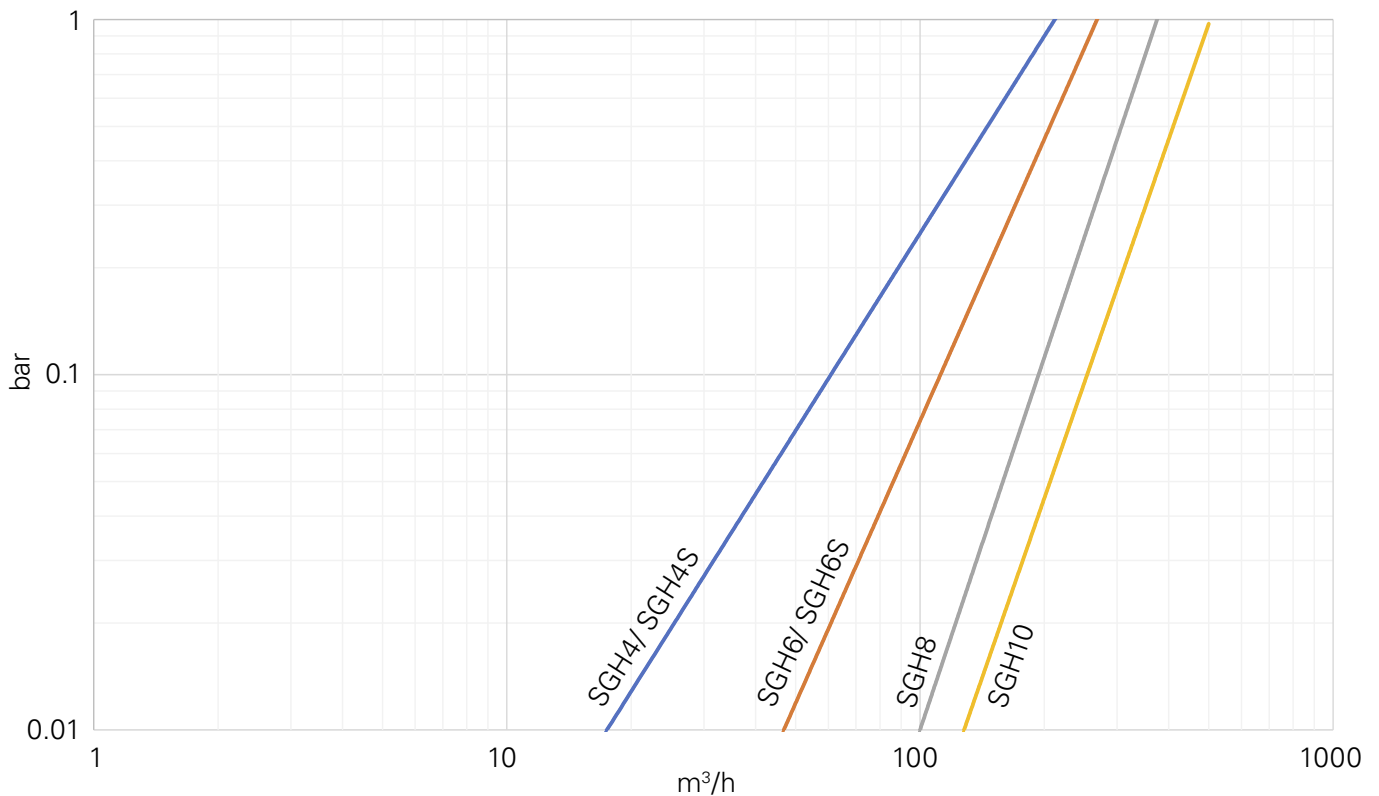

DESCRIPTION

SG1 Smart Bluetooth flush controller

New hardware design, professional properties, and high reliability make the SG1 the most efficient solution for the management of the SG filter.

Main features

PD based flushing cycle activation

The controller monitors the pressure differential between the inlet and outlet by means of a built-in PD sensor and triggers flushing cycles accordingly.

Smartphone application

Feature a user-friendly Smartphone application that communicates with the controller via Bluetooth (10 meter range of the controller!)

The application allows:

- Monitoring all the parameters of the filter's activity
- Reviewing the filter activity history
- Setting operational parameters: PD (pressure differential), PD delay, Flushing interval and operation mode
- Starting a flushing cycle
- Monitoring battery state

The application interfaces with multiple SG1 controllers, allowing monitor and control of many filters.

Manual flushing cycle activation

An external START button enables manual activation of a flushing cycle.

Endless looping detection

The SG controller monitors the number of consecutive flushing cycles triggered by the PD sensor before deciding that there is an endless looping problem. The options, controlled and monitored through the cellular application, are: 1-10 or "no," ignore the looping problem.

The flush controller does not require any adjustment, it is entirely factory adjusted for best operation.

- PD (pressure-differential) is set to 5 meters (0.5 bar)
- PD delay is set to 5 seconds
- Flushing interval is set to 4 hours
- The operation mode is set to Time & PD
- The controller is fully functional with or without the cellular application.

Batteries

The controller is powered by 4 x 1.5v C-size alkaline batteries (not supplied).



NOTE

If electricity is available at the filter location, the flush controller can be powered by an external 100-240v AC to 5v DC power supply (not supplied). (see [page 17](#))



WARNING

When operating the controller with the external power supply, make sure that the battery compartment is not inside the flush controller (its loose wire ends could cause short-circuit).



DESCRIPTION

Main parts

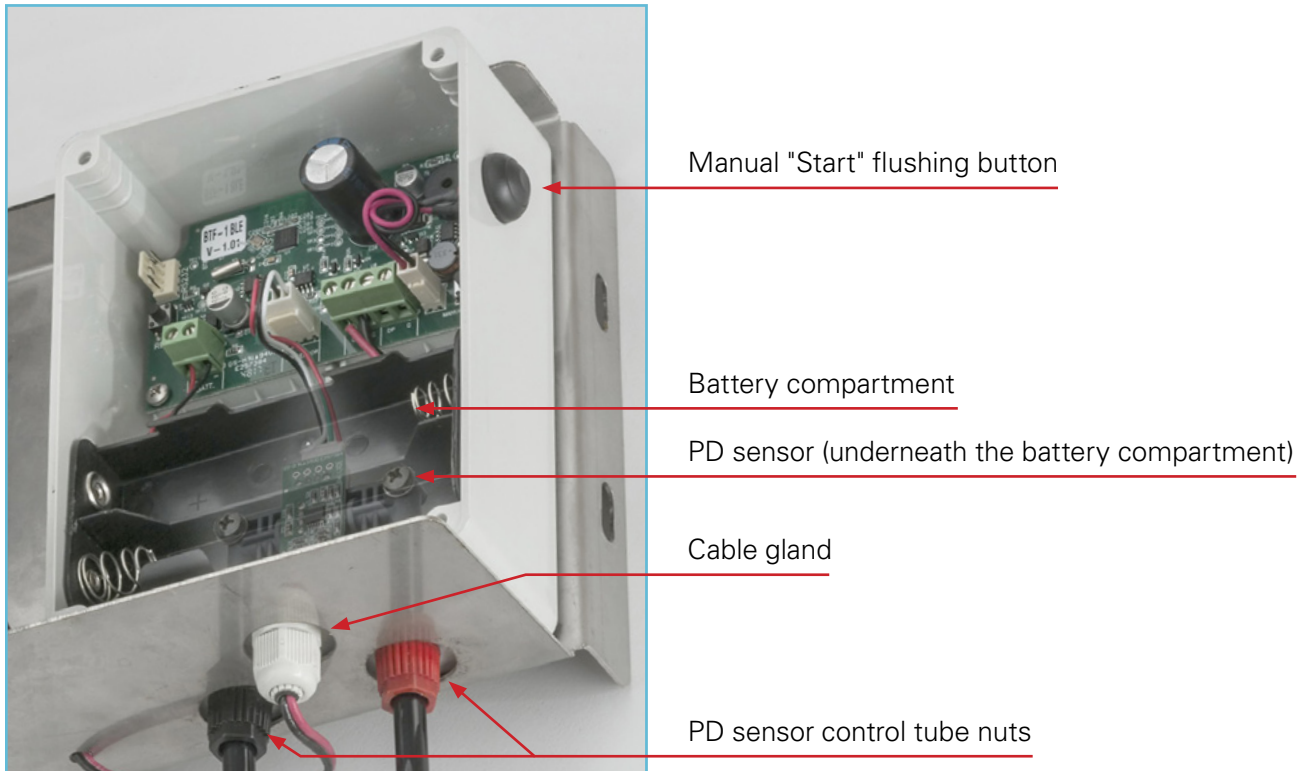

Wiring

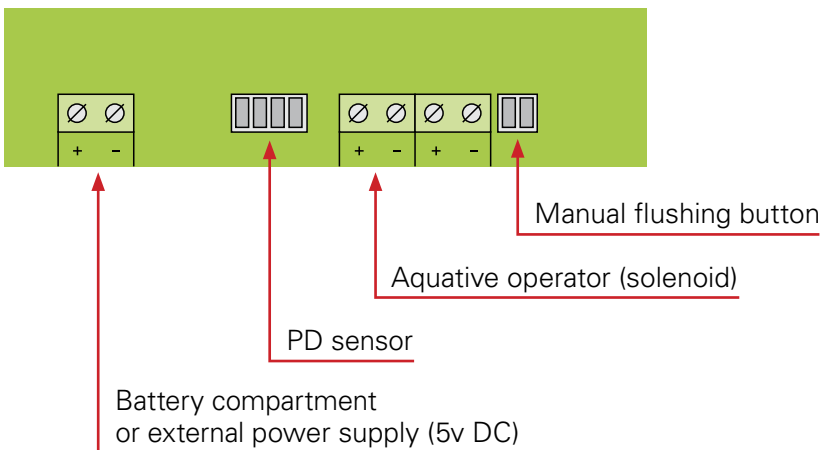

Option: Filtron 1-10 flush controller

Optionally, SG filters can be supplied equipped with the Filtron 1-10 flush controller for additional control features.

For operation of the Filtron 1-10 flush controller see its User Manual enclosed with it.

DESCRIPTION

Control tubes

The PE 8 mm command tubes are factory-installed and do not require any intervention during installation of the filter.

The control-tube connection scheme below is to be used as reference while troubleshooting the filter.

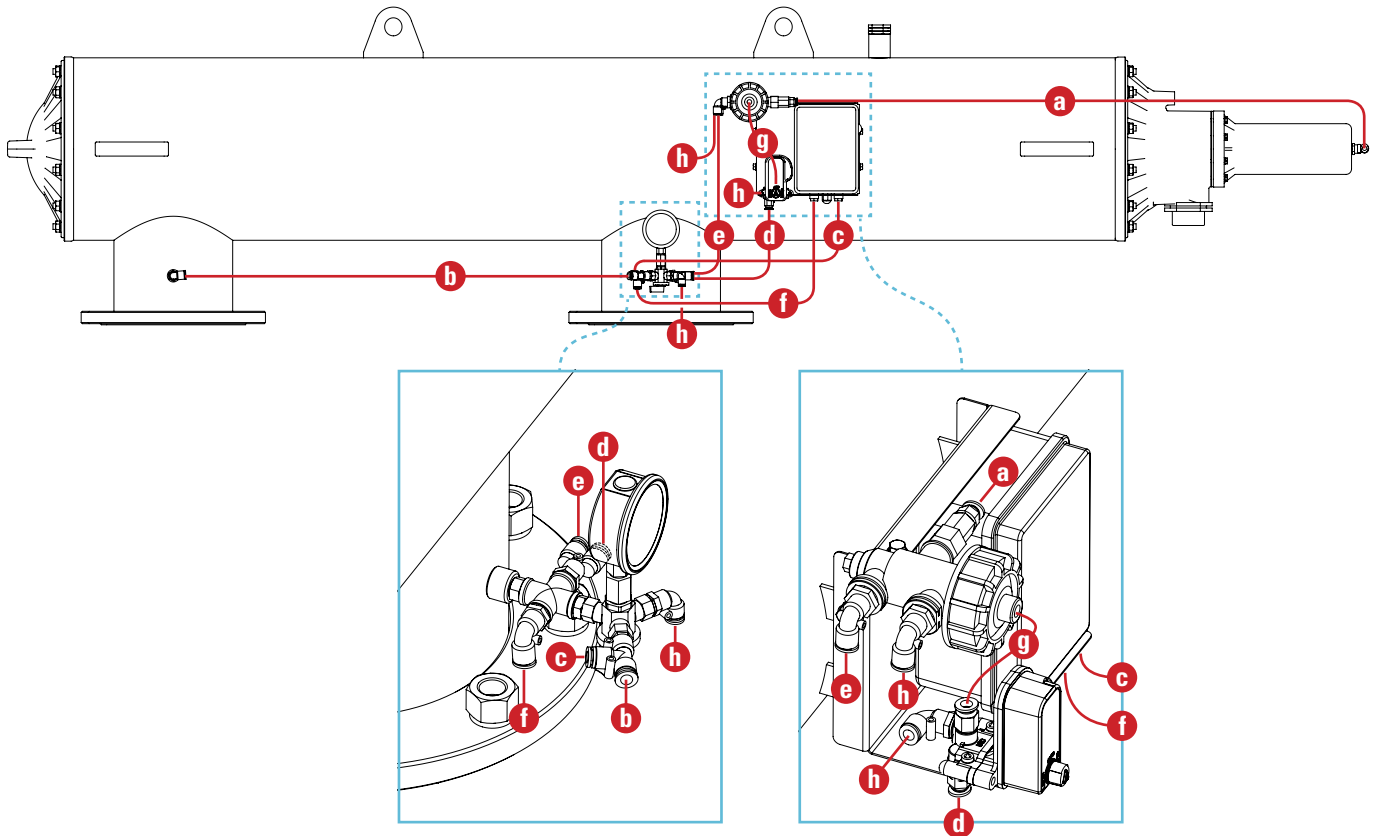

Legend

- a.** From the hydraulic valve to the filter hydraulic piston cap.
- b.** From the filter inlet pressure point to the pressure gauge 3-way valve.
- c.** From the filter outlet to the hydraulic valve.
- d.** From the filter outlet to the Aquative solenoid.
- e.** From the pressure gauge 3-way valve to the flush controller PD sensor high-pressure connection port (right).
- f.** From the filter outlet to the flush controller PD sensor low-pressure connection port (left).
- g.** From the Aquative solenoid to the hydraulic valve.
- h.** Drain tube (no more than 2 meter long each).

INSTALLATION

Pre-installation preparations

Design Recommendations

- If a long pipeline fill time causes a temporary high flow and low pressure situation, it is recommended to install a pressure-sustaining valve (PSV) downstream from the filter. The PSV will ensure a controlled fill-up of the line.
- It is highly recommended to install isolation valves upstream and downstream from the filter for maintenance and troubleshooting purposes.
- In case a PRV is required, it is highly recommended to install it downstream from the filter.
- It is highly recommended to install a mechanical non-return valve downstream of the filter to prevent backflow damage to the screen.
- Make sure that the filter location offers sufficient clearance to remove the cover assembly and the screen assembly from the filter for troubleshooting (see [page 8](#)).
- Avoid placing the flush pipe on a rising slope to prevent backpressure.
- Flush pipe diameter: Minimum 2".

Preparations for Installation

- Prepare the inlet and outlet pipes according to the dimensions and type of connection (thread/flange) of your filter (see [page 9](#)).
- Ensure suitable lighting at the area of the filter to enable good visibility and safe maintenance.
- Arrange suitable platforms and safety barriers to enable easy, safe access to the filter.
- Allow a convenient access and adequate space around the filter for dismantling and maintenance.

Tools required for installation

- Lifting device
- Hoisting straps
- Crosshead screwdriver
- Teflon thread seal tape (for drain pipe)
- Spanners

Flange size	Bolt and nut size	Wrench size
up to 8"	5/8" (17mm)	15/16"
10" to 14"	7/8" (24mm)	1.1/8"

Unpacking and placement

- Open the cardboard package and remove cardboard and support wooden frames.
- Attach straps to the hoisting points and secure the filter using a lifting device or support it manually.



ATTENTION

Note the filter weight before operation and follow the safety instructions.

- Detach the filter from the wooden pallet.

INSTALLATION

Hydraulic installation



ATTENTION

The inlet pipe should be of a diameter equal to or larger than the filter inlet diameter.
Never connect a the SG filter to an inlet pipe of a diameter smaller than the filter inlet diameter.

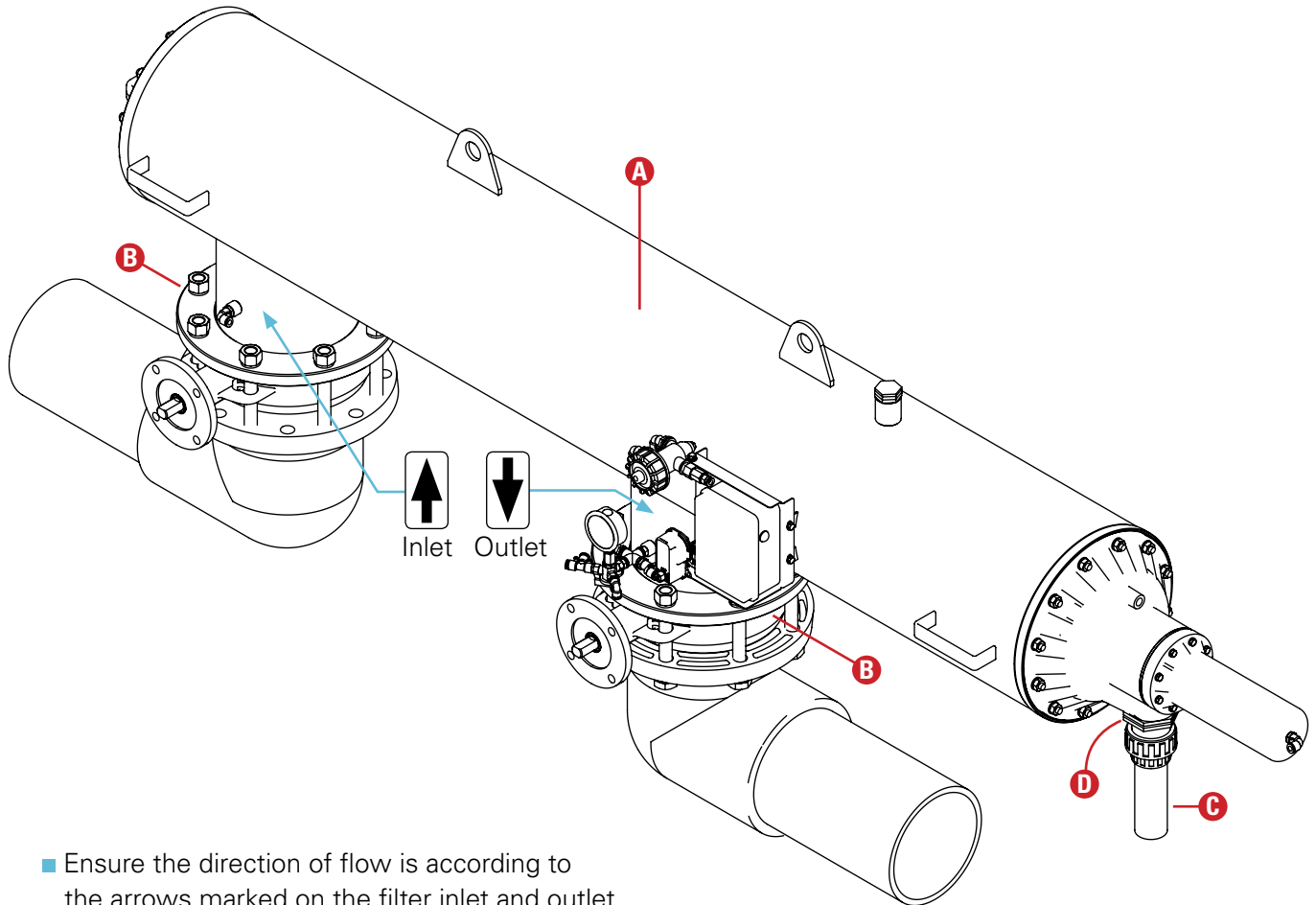

- Ensure the direction of flow is according to the arrows marked on the filter inlet and outlet.
- Place gaskets on the inlet and outlet flanges (B).
- Position the filter in place.
- Fasten the inlet and outlet flanges bolts.
- Connect a pipe (C) to the port (D).
Water should be allowed to flow to the atmosphere freely from the flush pipe.

Diameter	Length
2"	up to 10 m
3"	10-20 m (maximum 20m)

- Secure the open end of the flush pipe to prevent movement during the flushing cycle.
- Avoid placing the flush pipe on a rising slope to prevent backpressure.



ATTENTION

If a PRV is required in order to protect the irrigation system, it is highly recommended to install it downstream of the filter.

INSTALLATION

Bluetooth flush controller activation

Insert batteries into the Bluetooth flush controller



NOTE

Always use a whole set of 4 new batteries. Never use new and old batteries together.

1. Open the flush controller box using a cross-head screwdriver.

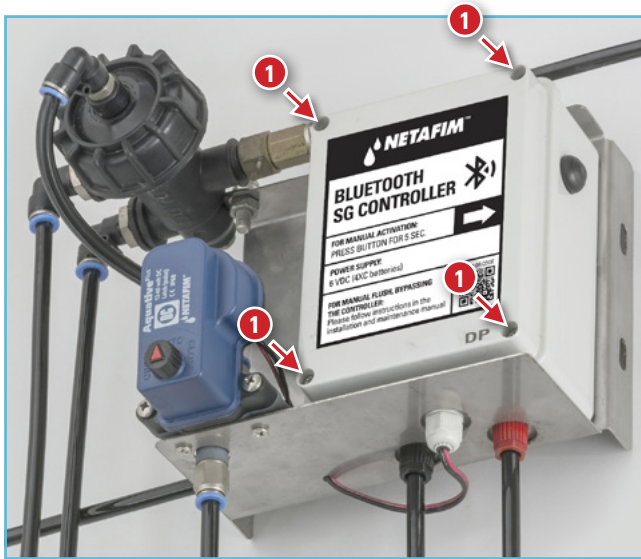

The controller should turn on automatically. 3 short beeps followed by a long one should be heard.

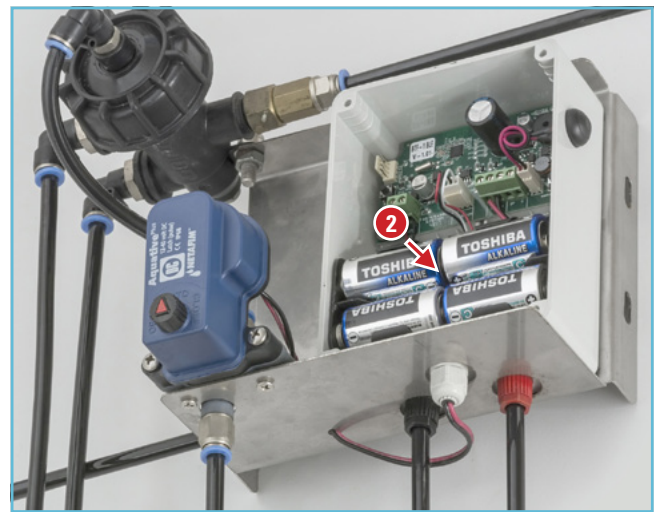

2. Insert a set of 4 new batteries (Match the poles to the markings inside the battery housing).

3. Close the flush controller box (mind the alignment of the cover gasket to ensure sealing).

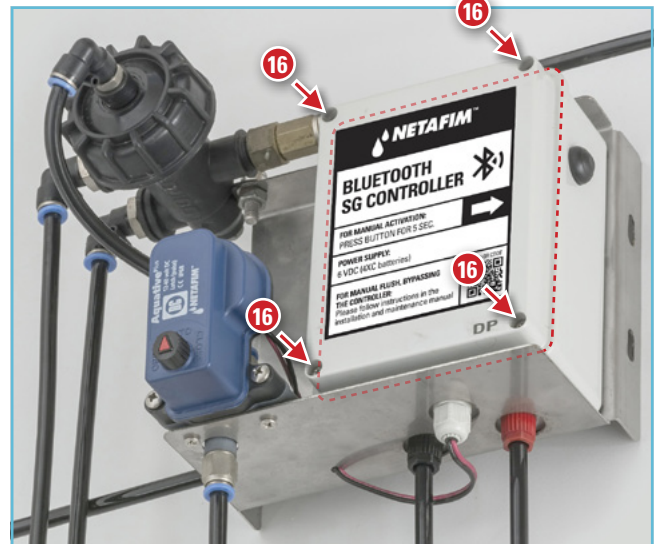

If your SG filter is equipped with the Filtron 1-10 flush controller, see its User Manual enclosed with it.

INSTALLATION

Download the SG filter application to your Smartphone

1. Scan the QR code (also on the flush controller) or download it from the appropriate app store and install it.

Notice that there are two application versions.

- For Android - On Google play
- For iOS - On Apple store



2. Follow the on-screen instructions.



TIP

After the installation, it is recommended to create a shortcut on your Home screen.

Link the SG filter application to the filter flush controller

Enter the SG1 Smartphone application and select your filter (BT pairing is automatic).

Scan the QR code on the flush controller to enter the user manual.

INSTALLATION

Power the flush controller by an external power supply

If electricity is available at the filter location, the flush controller can be powered by an external 100-240v AC to 5v DC power supply (not supplied).



1. Open the flush controller box using a cross-head screwdriver.

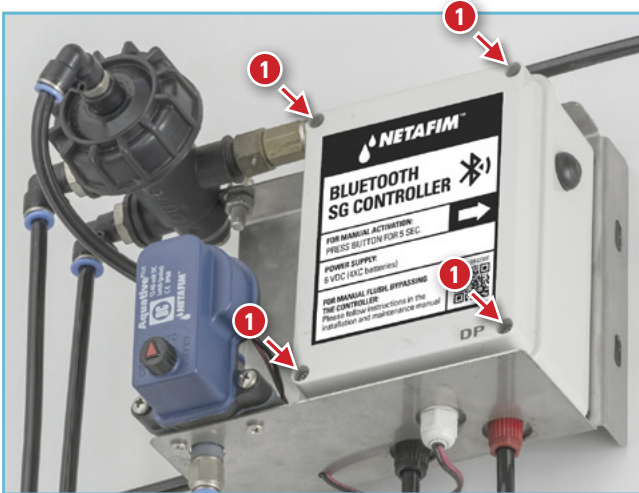

2. Disconnect the battery compartment wires from the terminal block using a flat-head screwdriver.
3. Remove the battery compartment and keep it separately for possible future use.
4. Loosen the cable gland nut by hand.

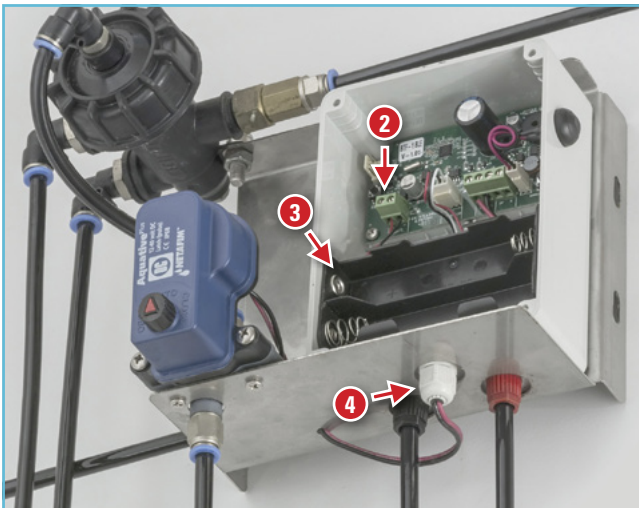

5. Gently thread the power supply wires through the cable gland.
6. Connect the power supply wires to the terminal block (mind polarity).
7. Refasten the cable gland nut by hand.
8. Plug the power supply to the mains and make sure the flush controller turns on.

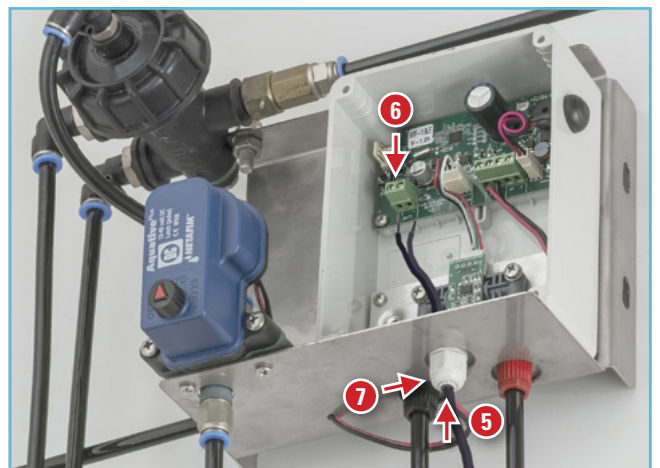

9. Close the flush controller box (mind the alignment of the cover gasket to ensure sealing).



WARNING

When operating the controller with the external power supply, make sure that the battery compartment is not inside the flush controller (its exposed wire ends could cause short-circuit).

If your SG filter is equipped with the Filtron 1-10 flush controller, see its User Manual enclosed with it.

INITIAL OPERATION

Preparations

Before activating the filter for the first time, go through the following check-list carefully (No special training is required to carry out these activities).

- Check that the filter is mounted in the correct flow direction.
- Check that all nuts and bolts are firmly tighten.
- Check that all the command tubes are connected properly and that all connections are tight (see [page 12](#)).
- Ensure the filter is well supported and stable.
- Check that the Aquative operator (solenoid) selector is turned to the AUTO position.
- Make sure that the flush pipe is installed in conformity with the specifications (see [Hydraulic installation](#), page 14).
- Make sure the controller is active by initiating a manual flush (The solenoid should click).
(To initiate a manual flush hold the MANUAL button on the flush controller pressed for 5 seconds or use the START command in the application.)

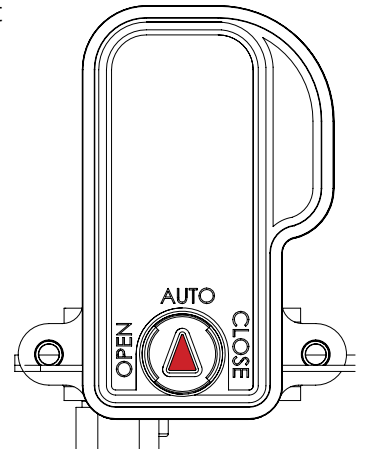

First operation

After completing the preparation check-list above, perform the following steps:

1. Slowly open the isolation valve at the filter inlet.
Water will flow into the filter.
2. Check for leaks and repair if necessary.
3. Slowly open the isolation valve at the outlet of the filter.
4. Ensure the flow through the filter does not exceed the filter's maximum flow rate (see [page 6](#)).
5. Start a manual flushing cycle.
(To initiate a manual flush hold the MANUAL button on the flush controller pressed for 5 seconds or use the START command in the application.)
6. Check the upstream pressure **during the flushing cycle**, it should not drop below 2.0 bar (30 PSI).
8. Perform 2 additional consecutive manual flushing cycles to evacuate air from the system.
9. Monitor the upstream pressure **during the flushing cycles**, it should not drop below 2.0 bar (30 PSI). If this cannot be ensured, consult Netafim™.

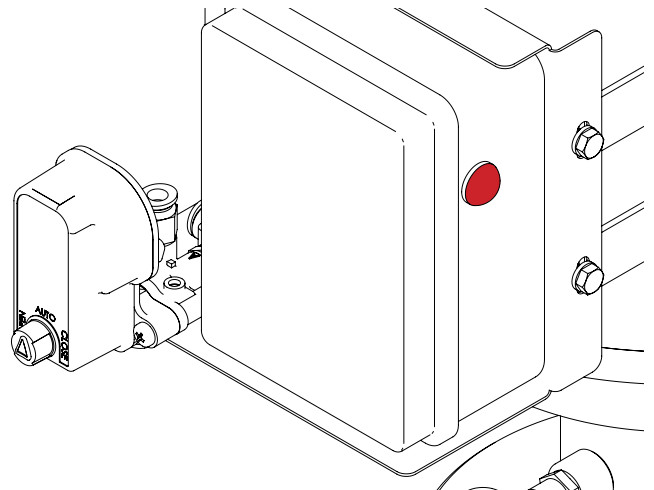

NOTE

The filter flushes in two, separate consecutive flushing cycles with a few seconds pause between them (During the pause the filter does not flush).

OPERATION

Application operation

The SG1 Smartphone application is easy-to-use and intuitive. The following is a quick guide to the SG1 app. (If your SG filter is equipped with the Filtron 1-10 flush controller, see its User Manual enclosed with it).

Welcome screen

When the user taps on the app shortcut, a welcome screen appears...



Scanning process screen

Then, a Scanning process of the controllers in the vicinity will start.

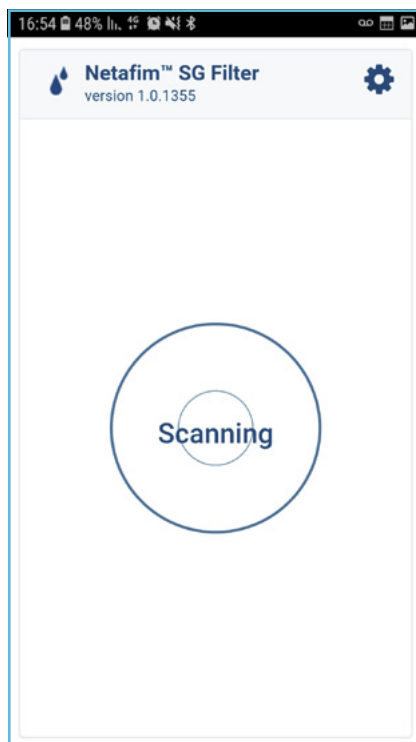

Scanning result screen

The results of the controllers in the vicinity will appear on the Scanning result screen.

Select your controller.

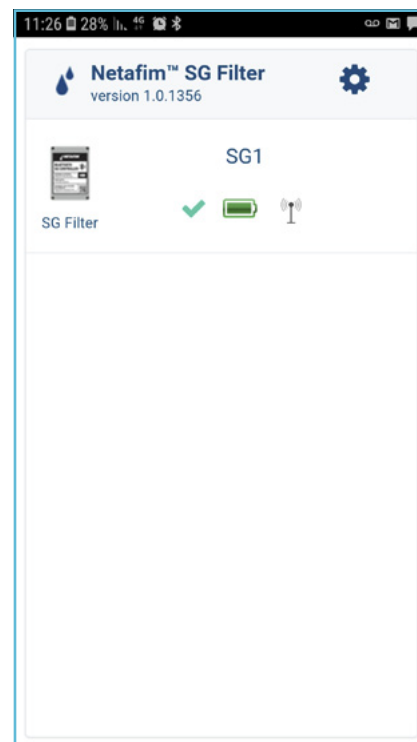

Continued on the next page

OPERATION

Your controller home screen

This screen displays the main parameters of the filter operation:

- Operation mode
- Flushing interval
- P.S. time
- PD set point

NOTE

The SG controller does not require any adjustment, it is entirely factory adjusted for best operation.

However, you can edit a parameter by pressing it.

WAIT PD - the application is acquiring PD data from the controller (wait before proceeding).

START - Press to start or stop a flushing cycle.

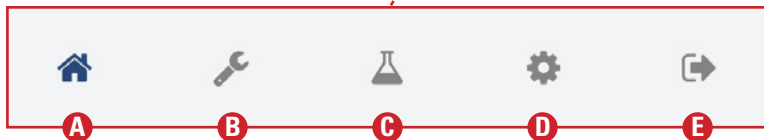
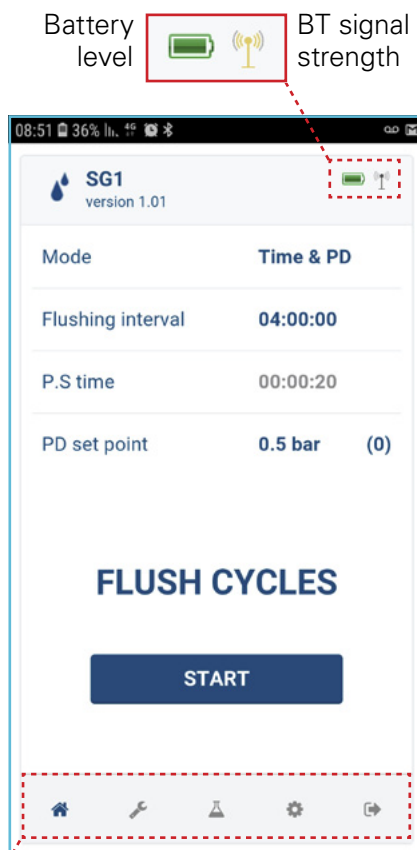

A. Home

- Mode
- Flushing interval

B. Settings

- PD delay
- Looping limit
- Device name
- Sound
- PD calibration

C. Flushing history

- Based on time
- Based on pressure differential
- Manual flushings
- Clear counters

D. Preferences

- Select language
- Select font size
- Technician mode (Only Netafim qualified technicians are authorized to this section by personal password).

Netafim™ SG filter

- Troubleshooting
- Contact Netafim™

E. Exit the SG1 app.

Operation mode selection screen

- Select
 - Suspended
 - PD only
 - Time and PD

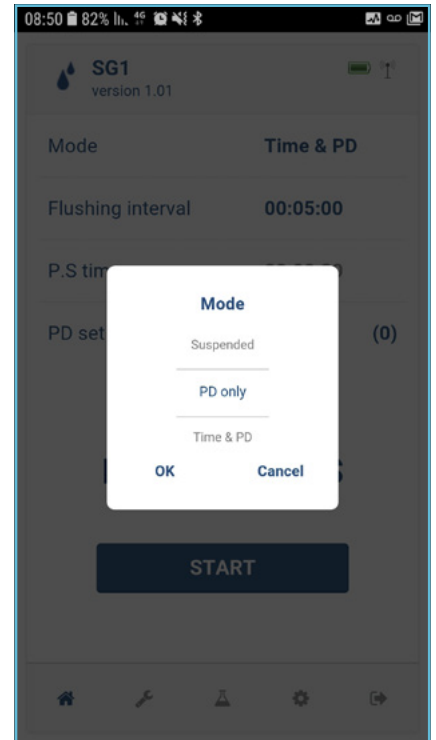

Flushing interval adjustment

Set time

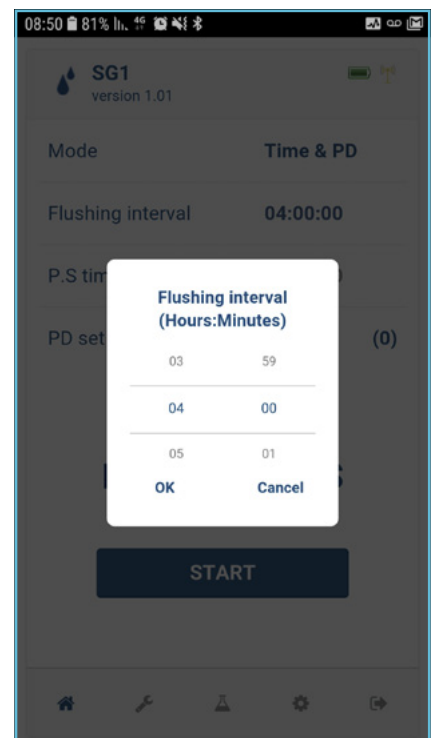

OPERATION

PD setpoint adjustment screen

Set PD setpoint

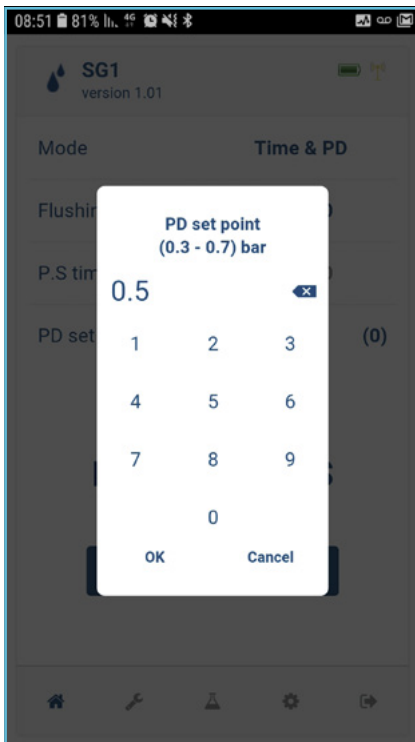

Settings screen

This screen displays additional parameters of the filter operation:

- PD (pressure differential) delay (not editable)
- Looping limit
- Controller's name
- Pressure unit - bar/PSI
- Sound - ON/OFF
- PD calibration activation

Press a parameter to edit it.

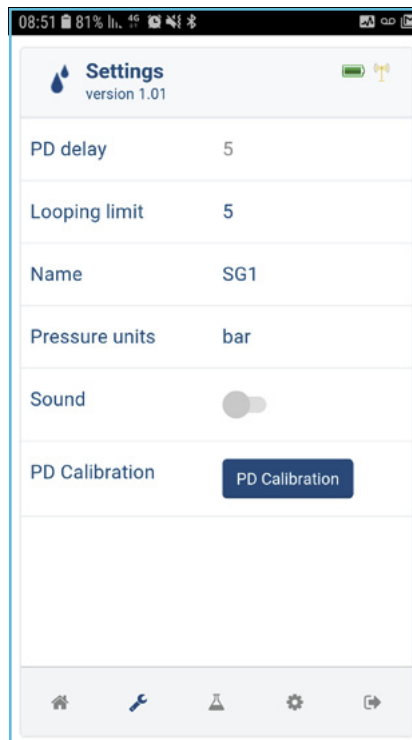

Set looping limit screen

Set the number of consecutive flushing cycles triggered by the PD sensor before deciding that there is an endless looping problem.

Enter a number - 1-10, or 0 - to ignore the looping problem.

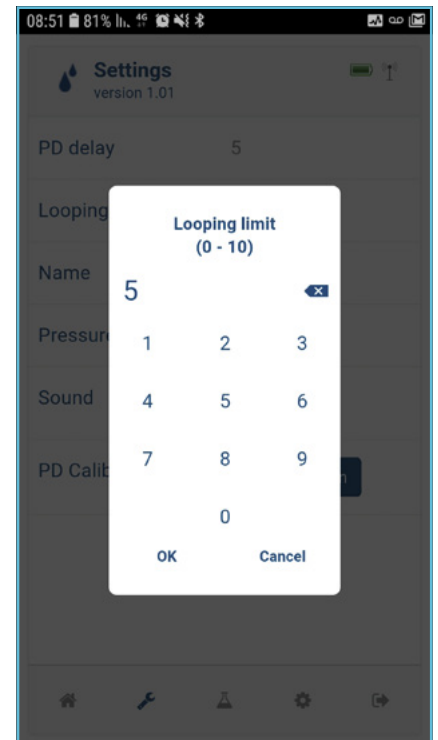

Continued on the next page

OPERATION

Controller's name screen

Name your controller for future identification.

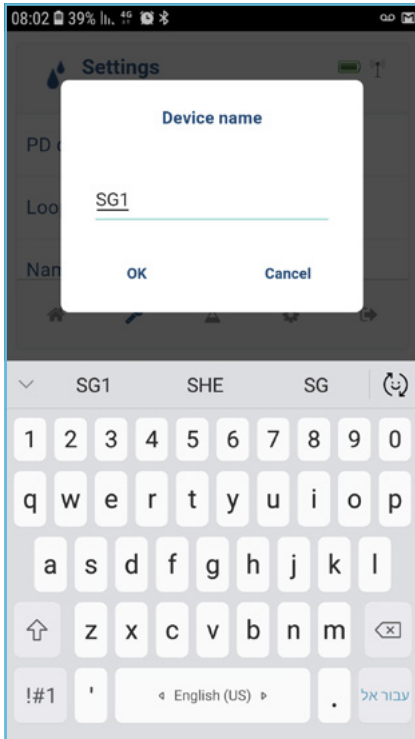

PD calibration screen

Initiate PD calibration.

ATTENTION

During calibration make sure both pressure tubes are at atmospheric pressure.

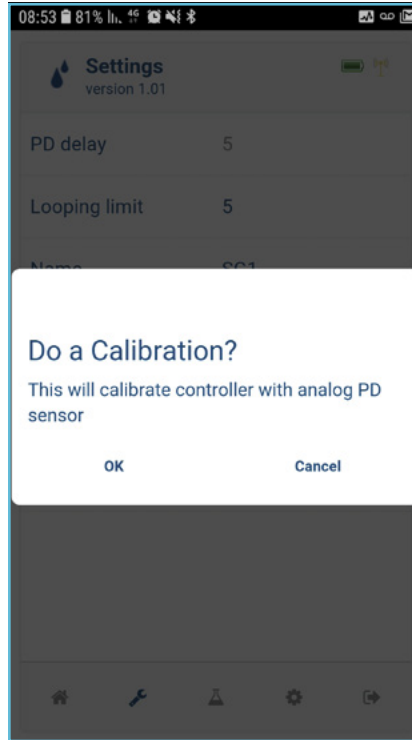

Enter your password
(Technician only)

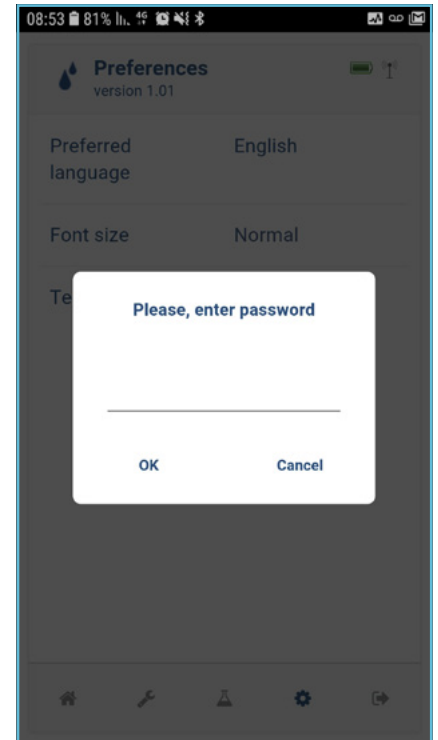

pressure unit screen

Select the pressure unit - bar/PSI

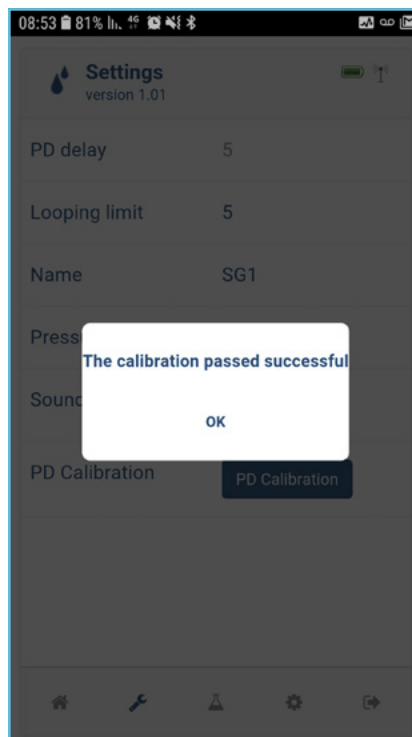
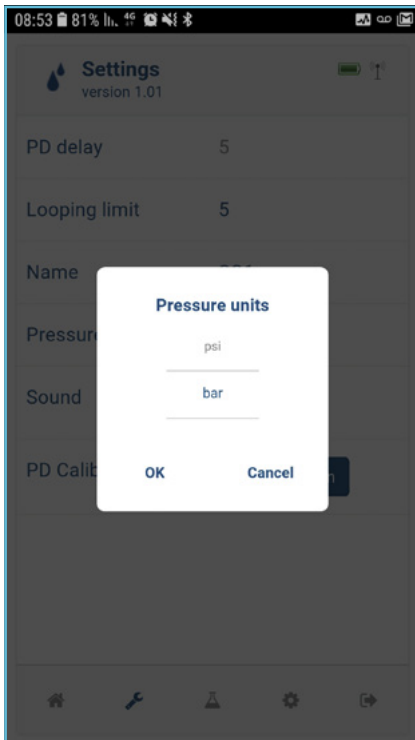

OPERATION

Manual flush cycle screen

Initiate a manual flush cycle

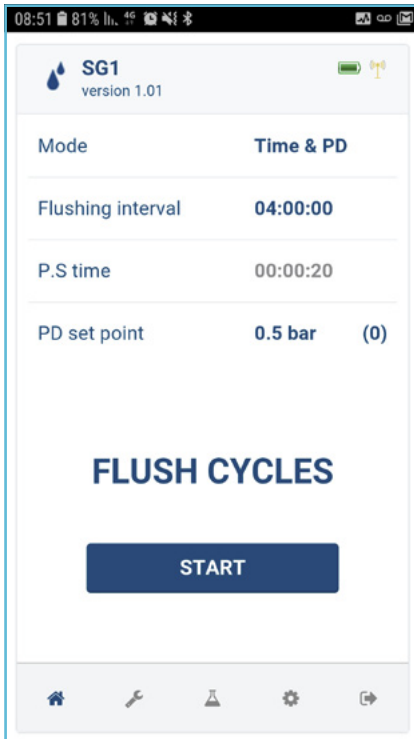

Stop a flush cycle screen

Stop a flush cycle in progress

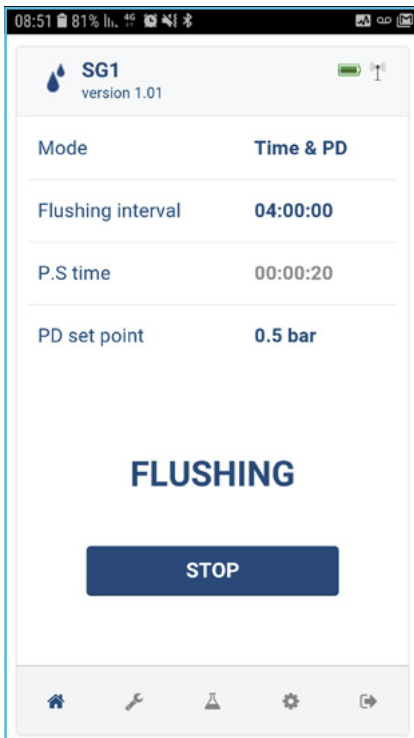

Your filter's Flushing history screen

This screen displays the accumulated number of flushings performed:

- Based on time
- Based on PD
- Manually triggered

This screen is not editable.

CLEAR COUNTERS - press to reset all the counters.

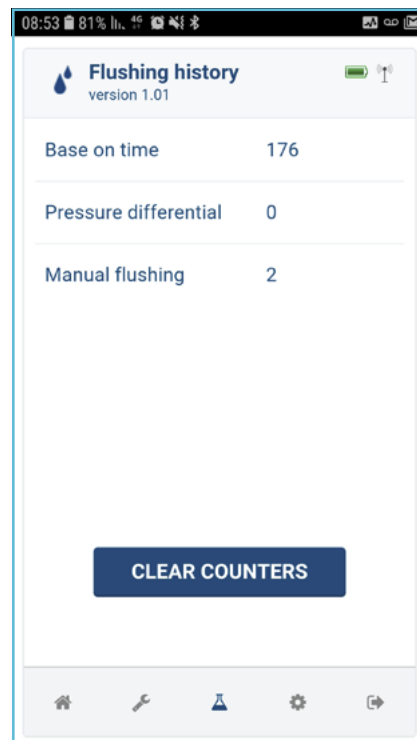

Continued on the next page

OPERATION

Preferences screen

This screen allows to select the app's UI language and font size.

Press a parameter to edit it (see the 2 next pages).

Technician mode - ON/OFF

ATTENTION

Only Netafim qualified technicians are authorized to this section by personal password.

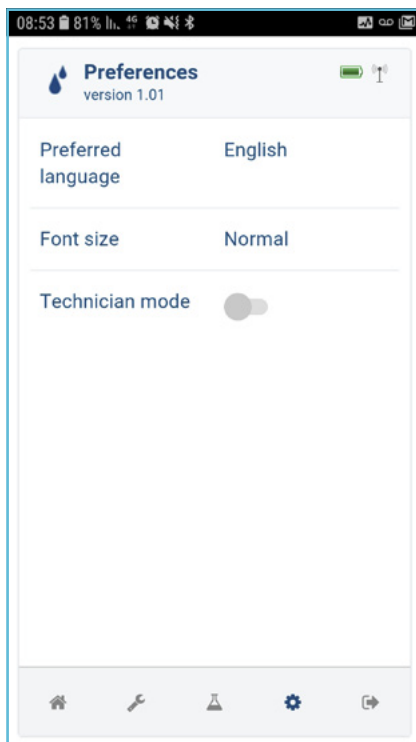

Select language screen

Select the app's UI language

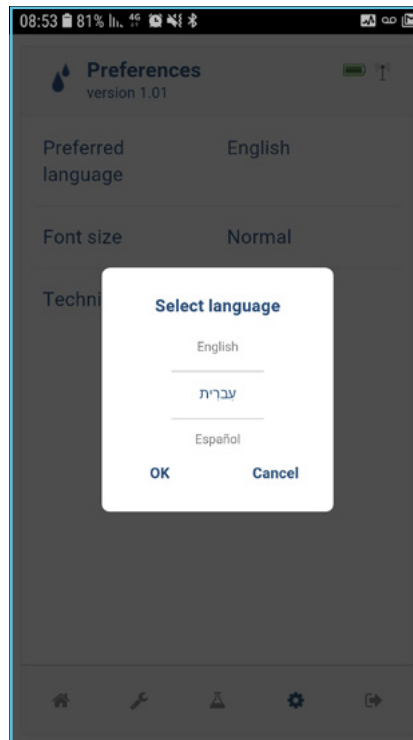

Troubleshooting screen

Restore BT connection

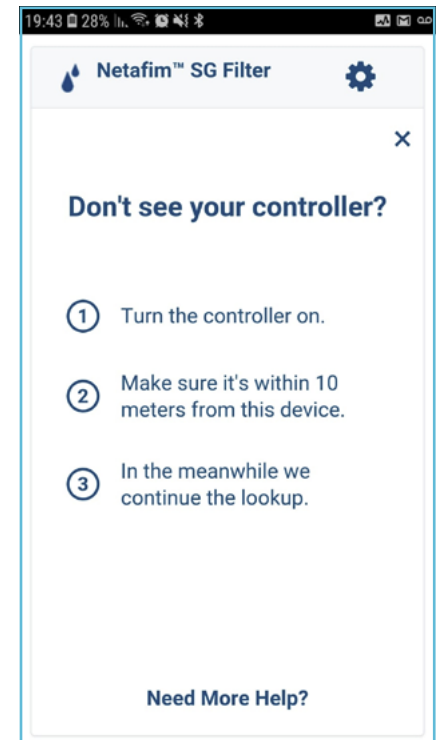

Select font size screen

Select the app's UI font size

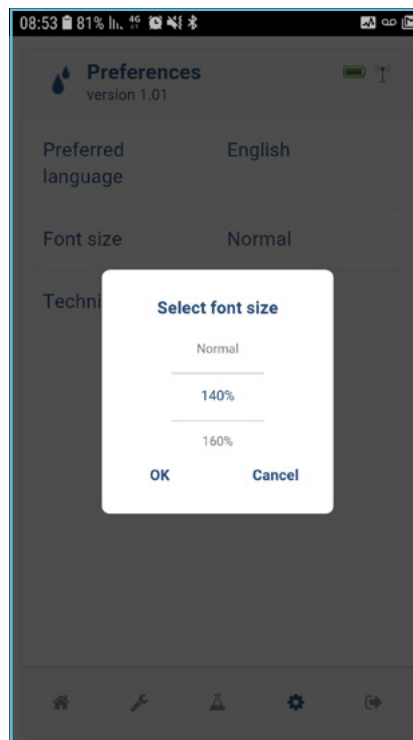

Contact screen



MAINTENANCE

Safety instructions



WARNING

When under pressure, the filter may start a flushing cycle automatically at any time, without prior indication. Fully release the pressure in the filter before performing installation or maintenance operations involving opening the filter. Check the pressure gauge to be sure it is at 0 before proceeding.

Tools required for maintenance

- Spanners - 17mm for the filter body, and 10mm for the piston
- Crosshead screwdriver
- Lubrication Grease - water resistant graphite/silicone grease

Maintenance schedule

Once a week

1. Visually inspect the filter and its control apparatus for leaks. Repair if necessary.
2. Perform a manual flushing cycle.
(To initiate a manual flush hold the MANUAL button on the flush controller pressed for 5 seconds or use the START command in the application).
3. Make sure that during the flushing cycle the inlet pressure does not drop below 2.0 bar (30 PSI).
4. Make sure the filter flushes in two, separate consecutive flushing cycles with a few seconds pause between them. In case a clear pause between the two flushing cycles is not noticeable, consult Netafim.

At the end of the irrigation season

1. Close the filter's downstream (outlet) valve.
2. Immediately perform 3 consecutive manual flushing cycles.
(To initiate a manual flush hold the MANUAL button on the flush controller pressed for 5 seconds or use the START command in the application.)
3. Turn the pump off.
4. Close the filter's upstream (inlet) valve.
5. Remove the batteries from the controller (see [page 27](#)).
6. Drain the filter.
7. Visually inspect the filter's body coating for damage. Repair if necessary (see [Paint retouching on the filter body](#), page 28).

At the beginning of the irrigation season

1. Extract the fine screen assembly and clean it with pressurized fresh water (see [page 26](#)).
if the screen is dirty with hard to remove organic dirt: Perform chemical cleaning of the filter screen assembly (see [Algae growth control](#), page 28).
2. Visually inspect the gaskets. Replace if necessary.
3. Visually inspect the upper bearing. Replace if necessary.
4. Visually inspect the lower bearing. Replace if necessary.
5. Visually inspect the suction nozzles for cracks and/or other mechanical damage.
6. Apply grease to the O-rings.
7. Install new batteries in the controller (see [page 27](#)).
8. Activate the filter (see [First operation](#), page 18).
9. Perform 3 consecutive manual flushing cycles
(To initiate a manual flush hold the MANUAL button on the flush controller pressed for 5 seconds or use the START command in the application.)
10. Make sure that during the flushing cycles the inlet pressure does not drop below 2.0 bar (30 PSI).

MAINTENANCE

Screen assembly cleaning



ATTENTION

Do not attempt to extract the screen assembly from the piston-side of the filter, it might damage the filter.

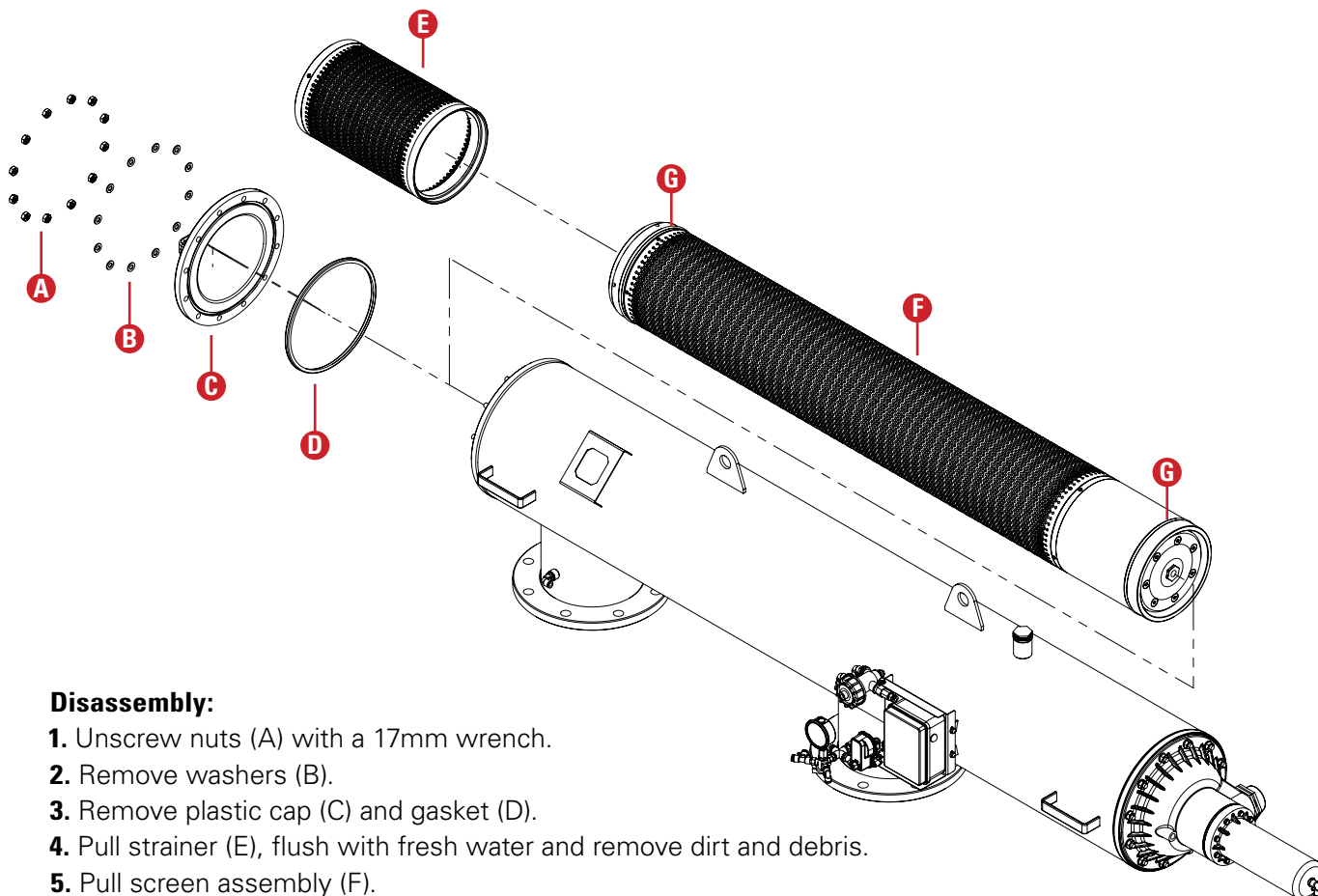

Disassembly:

1. Unscrew nuts (A) with a 17mm wrench.
2. Remove washers (B).
3. Remove plastic cap (C) and gasket (D).
4. Pull strainer (E), flush with fresh water and remove dirt and debris.
5. Pull screen assembly (F).
6. Flush screen assembly (F) from the outside in with pressurized water and remove dirt.

If the screen is still dirty, separate the flushing assembly from the screen assembly (see [page 32](#)) and flush screen assembly (F) from the inside out with pressurized water and remove remaining dirt.

Assembly:

If the flushing-assembly has been separated from the screen assembly, rejoin them (see [page 32](#)).

1. Lubricate screen assembly O-rings (G).
2. Insert screen assembly (F) (mind screen direction) and push all the way in.
3. Insert the strainer (E).
Make sure the strainer (E) is aligned and positioned inside the socket of the screen assembly (F).
4. Make sure gasket (D) is in place, and position plastic cap (C) in place.
5. Place washers (B) and nuts (A) and tighten the nuts.

MAINTENANCE

Replacing the batteries in the Bluetooth flush controller

The controller is powered by 4 x 1.5v C-size batteries (6v DC):



NOTE

Always replace the whole set of 4 batteries. Never use new and old batteries together.

1. Open the flush controller box using a cross-head screwdriver.
4. Close the flush controller box (mind the alignment of the cover gasket to ensure sealing).

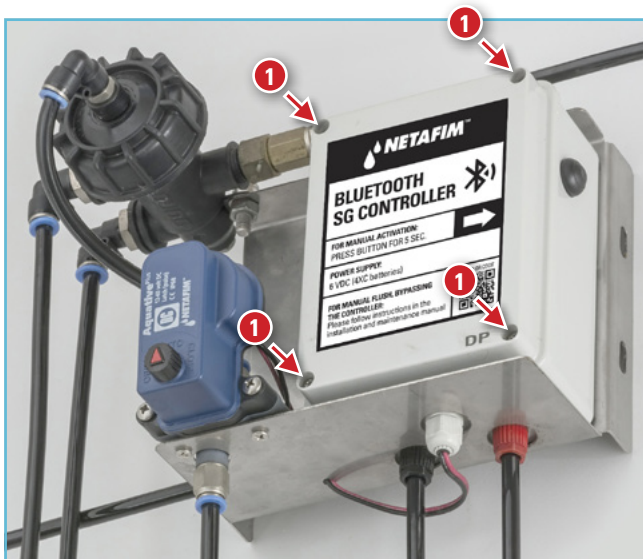

2. Extract the batteries.

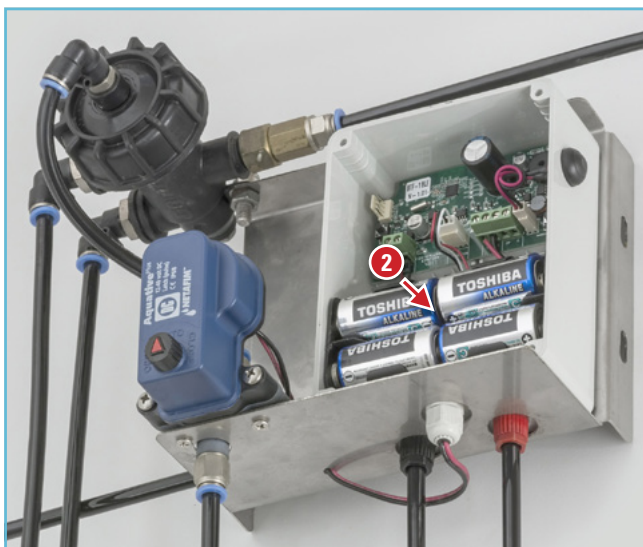
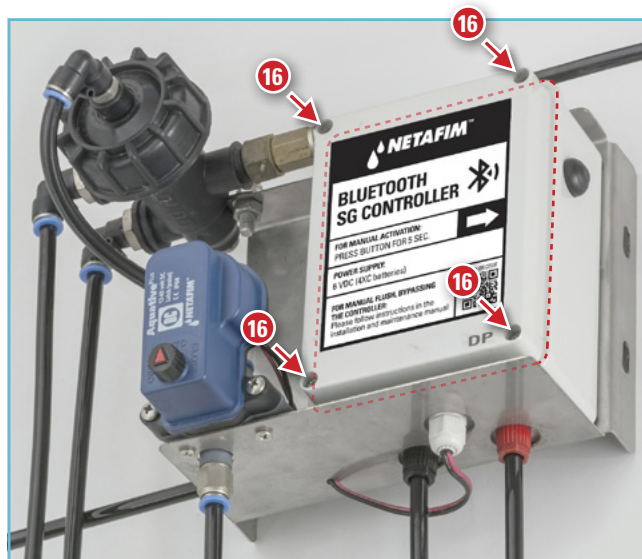

3. Insert a set of 4 new batteries (Match the poles to the markings inside the battery housing).

The controller should turn on automatically.
3 short beeps followed by a long one should be heard.

If your SG filter is equipped with the Filtron 1-10 flush controller, see its User Manual enclosed with it.

MAINTENANCE

Paint retouching on the filter body



WARNING

If the protective coating (inside and outside) of the filter body is damaged and the bare metal is exposed, it will rust in contact with irrigation water and chemicals. If neglected, this will lead to a leak.

Any damage to the protective coating of the filter body must be repaired as soon as possible.

Use Interseal® 670HS Surface Tolerant Epoxy protective paint, color: RAL 5010.

1. Sand the damaged area or spot with sandpaper and clean it with a wire brush.
2. Apply the protective paint.
3. Let the paint completely dry for at least 24 hours before exposing the mended spot to water.

For further assistance, contact your local Netafim™ representative.

Algae growth control



WARNING

Sodium hypochlorite (NaClO) is dangerous toxic and corrosive chemicals. All application regulations and safety rules must be observed. Store and handle according to safety regulations.

Before handling **sodium hypochlorite (NaClO)**, carefully read all the specific safety, health protection and first aid information and instructions. **Be sure you have all required first aid at the site, as instructed.**

Concentrated liquid sodium hypochlorite (NaClO) can damage exposed metal (especially threads that are exposed to water). Be careful when applying them and avoid the spillage of any of the liquid onto exposed metal parts. Should any of the liquid come into contact with metal parts, immediately wash thoroughly with fresh water.

1. Prepare a 15% sodium hypochlorite solution in an acid resistant container able to contain the filter screen assembly.
2. Remove the gaskets from the screen assembly.
2. Dip the filter screen assembly in the solution for 30 minutes (it should be completely submerged in the solution).
3. Rinse the filter screen assembly with fresh water.

For further assistance, contact your Netafim™ local representative.

MAINTENANCE

Winterization

Filter operation should be suspended in climates where the filter is exposed to freezing temperatures.

At the end of the irrigation season

- Close the downstream isolation valve and perform 3 manual flushes.
(To initiate a manual flush hold the MANUAL button on the flush controller pressed for 5 seconds or use the START command in the application.)
- Turn the pump off.
- Close the inlet valve to the filter and release the pressure.
- Drain the filter.
- Disconnect all command tubes from the valves and flush controller. Drain them of water and re-connect (Mind the command tube connection scheme, [page 12](#)).
- Visually inspect the filter's body coating for damage. Repair if necessary (see [Paint retouching on the filter body](#), page 28).

At the beginning of the next irrigation season

See [First Operation](#), page 18.

TROUBLESHOOTING

General malfunctions

Problem	Possible causes	Solution
No water pressure or too low water pressure at the field valve/s.	<ul style="list-style-type: none"> ■ Pump malfunction. ■ PSV/PRV malfunction. ■ Pipe breach. ■ The filter is heavily clogged. 	<p>Check the pump, the PSV/PRV and the mainline pipe upstream from the filter.</p> <p>If found in working order: check the filter outlet and inlet pressures.</p> <p>If the pressure differential is higher than 0.5 bar (7 PSI):</p> <ol style="list-style-type: none"> 1. Close the filter's downstream (outlet) valve. 2. Immediately perform 3 consecutive manual flushing cycle (To initiate a manual flush hold the MANUAL button on the flush controller pressed for 5 seconds or use the START command in the application.) Make sure that during the flushing cycle the pressure does not drop below 2.0 bar (30 PSI). 3. Open the downstream valve. <p>If normal functioning is not restored, perform Screen assembly cleaning (see page 26).</p>
Filter flushing occurs at a much higher frequency than usual.	<ul style="list-style-type: none"> ■ Degraded water quality ■ Seasonal algae growth. ■ Too low inlet pressure. ■ The filter is heavily clogged. ■ Restriction on the flush line. 	<ul style="list-style-type: none"> ■ If water quality problems and algae presence have been dismissed, check the filter inlet pressure. <p>If it is in range:</p> <ol style="list-style-type: none"> 1. Close the filter's downstream (outlet) valve. 2. Immediately perform 3 consecutive manual flushing cycle (To initiate a manual flush hold the MANUAL button on the flush controller pressed for 5 seconds or use the START command in the application). <p>If normal functioning is not restored, perform Screen assembly cleaning (see page 26).</p>
Filter PD > 0.5bar	<ul style="list-style-type: none"> ■ Controller is not working. ■ Control valve is not working. ■ PD sensor is not working. 	<ol style="list-style-type: none"> 1. Make sure the controller is in working order by initiating a manual flushing cycle (To initiate a manual flush hold the MANUAL button on the flush controller pressed for 5 seconds or use the START command in the application). If it does not work, replace the batteries (see page 27). If it still does not work, consult your Netafim™ local representative. 2. Operate the Aquative manually (see page 18). If not working, perform Screen assembly cleaning (see page 26). If working, replace the Aquative (see page 35). 3. Compare PD in the application to actual PD. If inconsistent, perform callibration (see page 22). If the problem persists, replace the PD sensor (see page 36).

Operation

The following pages present all the technical processes needed to address any of the above malfunctions.



WARNING

Do not attempt any dismantling of the filter beyond the processes described in this chapter.

For further assistance contact your Netafim™ local representative.

TROUBLESHOOTING



WARNING

Do not attempt to extract the screen assembly from the piston-side of the filter, it will damage the filter.

Filter body opening - strainer side, and Screen assembly extraction

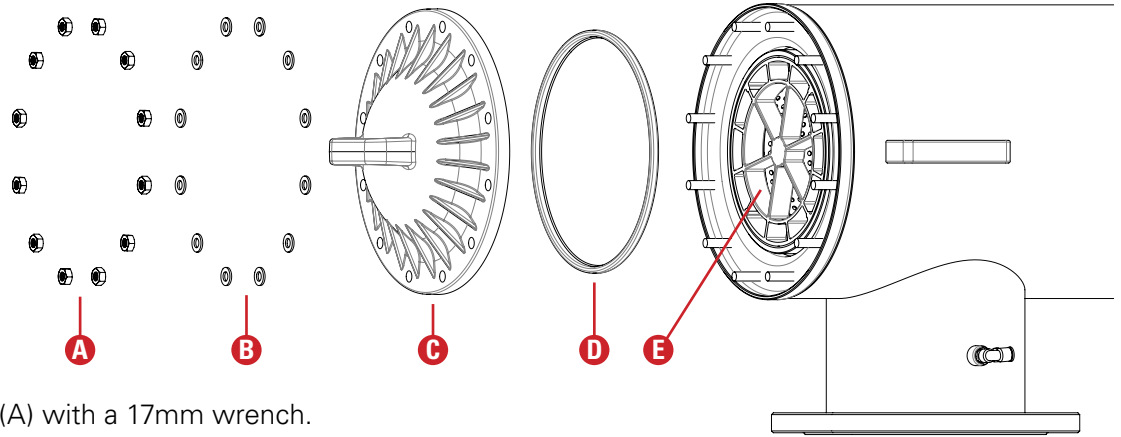

Disassembly:

1. Unscrew nuts (A) with a 17mm wrench.
2. Remove washers (B).
3. Remove Piston Cover Assembly (C) and gasket (D).
4. Pull the screen assembly (E) out of the filter body.

Assembly:

1. Lubricate screen assembly O-rings (see [Screen assembly cleaning](#), page 26)
2. Insert screen assembly (E) into the filter body (mind screen direction), and push all the way in.
3. Place gasket (D) in its groove (make sure it is properly placed).
4. Place Piston Cover Assembly (C).
5. Place washers (B) and nuts (A) and tighten the nuts.

Filter body opening - piston side

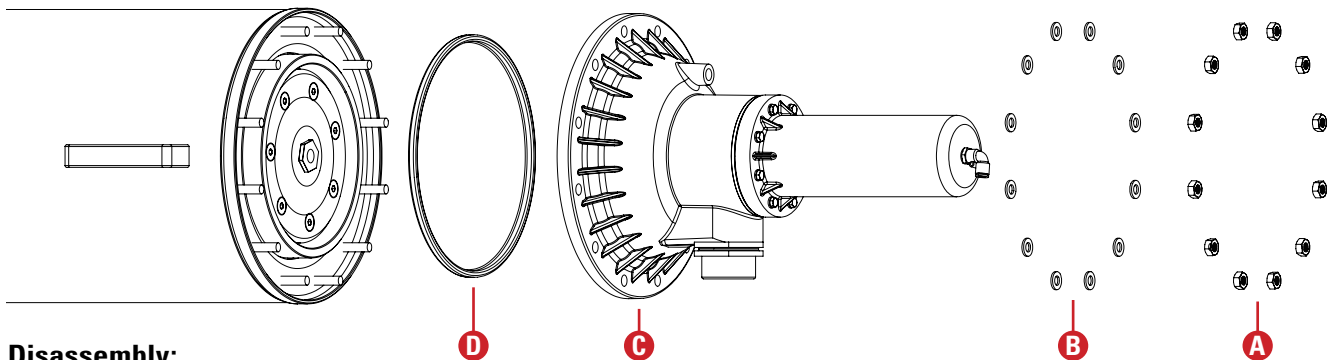

Disassembly:

1. Unscrew nuts (A) with a 17mm wrench.
2. Remove washers (B).
3. Remove Piston Cover Assembly (C) and gasket (D).

Assembly:

1. Place gasket (D) in its groove and make sure it is properly placed.
2. Place Piston Cover Assembly (C).
3. Place washers (B) and nuts (A) and tighten the nuts.

TROUBLESHOOTING

Flushing-assembly release

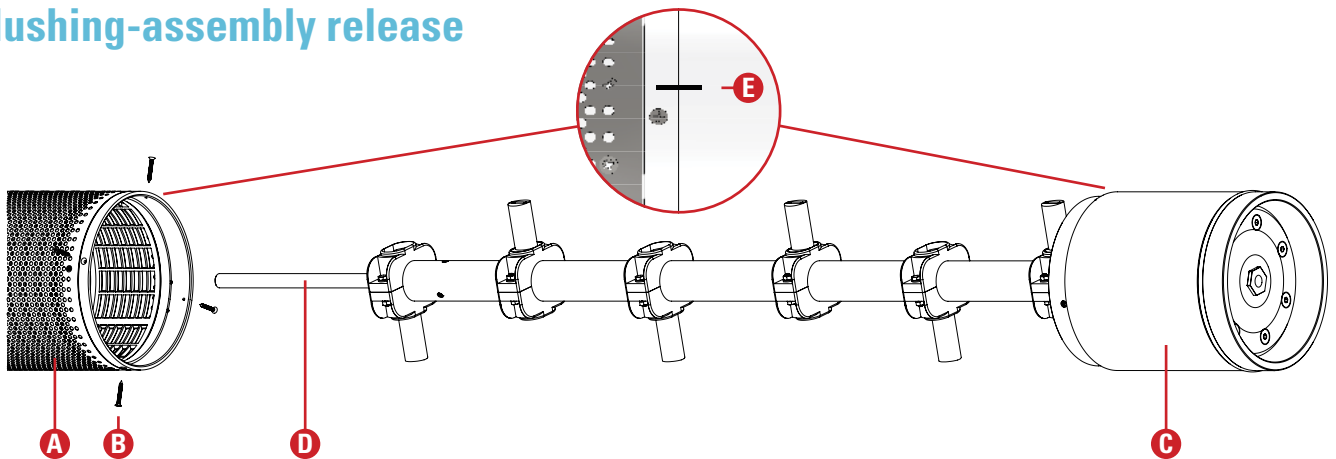

Disassembly:

1. Manually unscrew 4 screws (B) with a crosshead screwdriver.
2. Release the flushing assembly (C) from the screen assembly (A).
TIP To facilitate separation: First, gently push the main shaft (D) from the other side of the screen assembly (A) until the two parts are separated.
3. Pull the flushing assembly (C) from the screen assembly (A) holding the screen assembly (A) [do not hold the main shaft (D)].

Assembly:

1. Insert the flushing assembly (C) to the screen assembly (A).
Make sure the alignment mark (E) is aligned.
2. Make sure the 4 screw-holes are aligned between the two assemblies (A and C).
3. Hand tighten the 4 screws - do not use electric or impact tools.
4. Check that the suction element (D) moves and rotates freely inside the screen assembly.

Flushing-nozzle replacement

Disassembly:

1. Release the flushing assembly (C) from the screen assembly (A) as described above.
2. Unscrew 2 screws (F) with a 10mm wrench.
3. Separate the nozzle clamp set from the collector pipe (K).

Assembly:

1. Place the flushing nozzle (J) on top of the hole (L).
2. Place one clamp (I) onto the flushing nozzle (J).
3. Place the second clamp (I) opposite the first one, clenching the collector pipe (K).
4. Place a spring washer (G) on each screw (F) and insert through the 2 clamps (I).
5. Place a spring washer (G) and a nut (H) on the other end of each screw (F).
6. Hand-tighten the 2 nuts (H) with a 10mm wrench - do not use electric or impact tools.
7. Reattach the flushing assembly (C) to the screen assembly (A), as described above.
8. Check that the suction element moves and rotates freely inside the screen assembly.

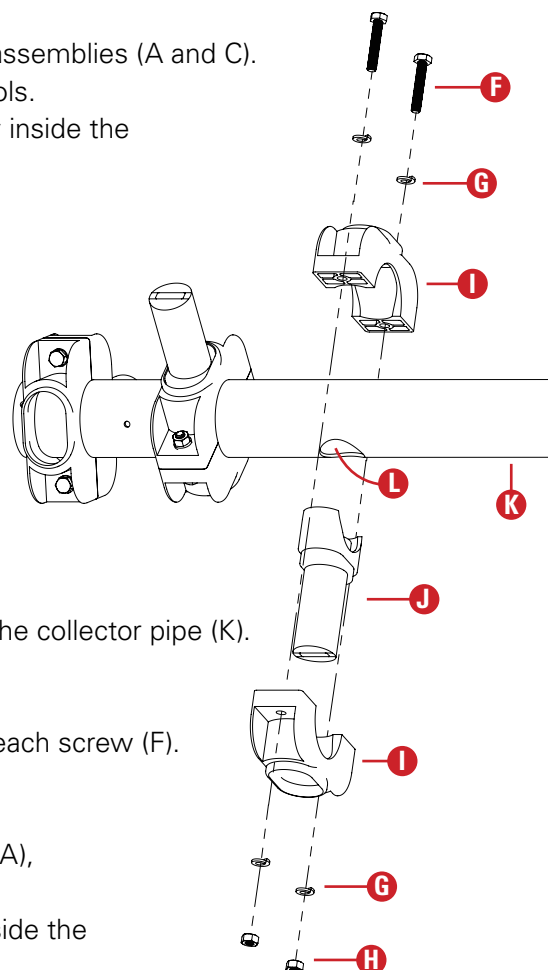

TROUBLESHOOTING

Piston-gasket replacement

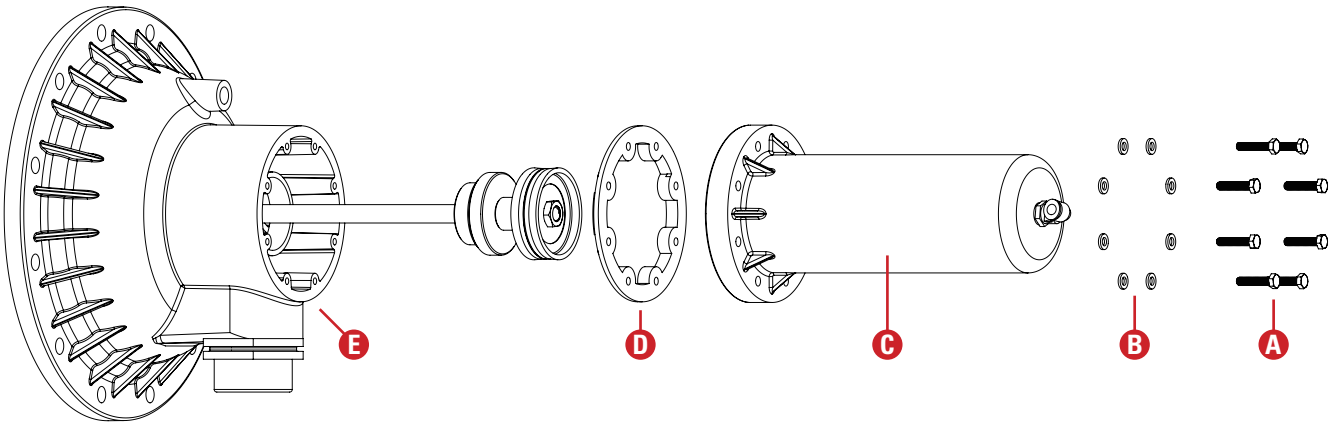

Disassembly:

1. Remove 8 screws (A) with a 10mm wrench
2. Remove washers (B)
3. Pull piston cylinder (C)
4. Remove gasket (D)

Assembly:

1. Place gasket (D) inside piston cylinder (C)
(Mind gasket orientation, flat side towards piston cap)
2. Place piston cylinder (C) on piston cap (E)
3. place washers (B) and hand-tighten screws (A)

Piston Seal replacement

Disassembly:

1. Release nut (A) while holding nut (B) with two 19mm wrenches.
 - If nut (A) is released: Remove the piston seal (H).
 - If nut (B) is released:
 - Remove washers (C) and plastic spacer (D). Under the plastic spacer (D) you will find a recess (E) on the rod (F).
 - Hold this recess (E) to prevent rotation of the rod (F) and release nut (A) with a 19mm wrench. Do not extract the rod (F) from the piston cover (G).
 - Remove the piston seal (H).
 - Put the plastic spacer (D), washers (C) and nut (B) back in place.

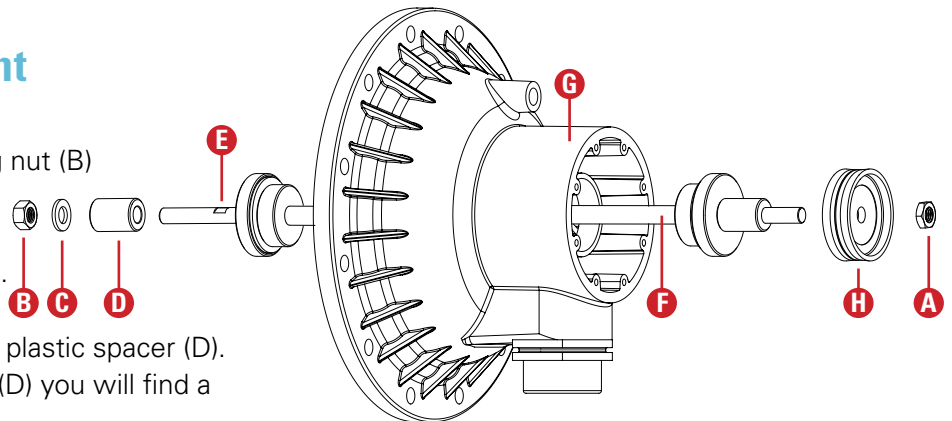

Assembly:

1. Place a new piston seal (H).
2. Hold nut (B) to prevent rotation of the rod (F) and tighten nut (A) with a 19mm wrench.
4. Apply grease to the piston seal (H).

Turbine Brass Bearing replacement

Disassembly:

1. Remove the turbine brass bearing (A) from the turbine set (B) with a 32mm wrench.

Assembly:

1. Place a new turbine brass bearing in its stead. Tighten properly.

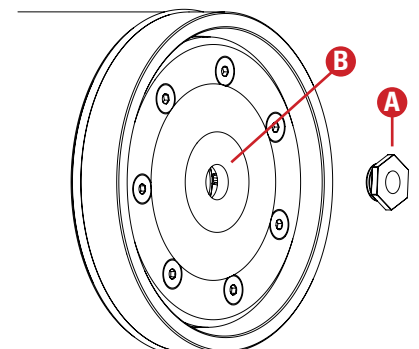

TROUBLESHOOTING

Centering Ring with Bearing replacement

Disassembly:

1. Manually unscrew 4 screws (A) with a crosshead screwdriver.
2. Pull the centering ring with bearing (B) from the screen assembly (C).

Assembly:

1. Insert a new centering ring with bearing (B) into the screen assembly (C). Make sure the suction assembly shaft (D) is aligned and properly inserted into the bearing (E).
2. Manually rotate the suction assembly. It should rotate freely.
3. Hand-tighten 4 screws (A) with a crosshead screwdriver. Do not use electric or impact tools.

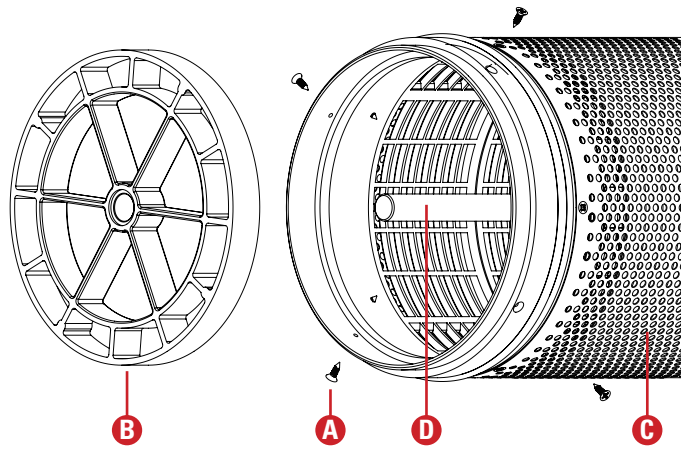

Control tube fast connector

Connection:

1. Make sure the tip of the tube is cut neatly and straight.
2. Simply insert the tube all the way into the fast connector.
3. Slightly pull the tube back to make sure it is properly inserted.

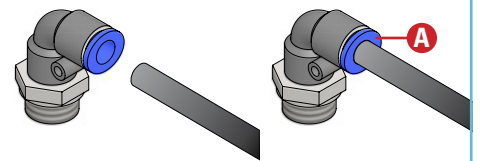

Disconnection:

1. Push back and hold the blue locking ring (A) and pull the tube out of the fast connector.

Hydraulic relay replacement

Disassembly:

1. Disconnect the control tubes from the 4 fast connectors (A).
2. Disconnect the brass connector adaptor (B) from the hydraulic relay (C) with a 10mm wrench to release the hydraulic relay assembly from the controller support bracket (D).
3. Disconnect the 3 fast connectors (A) from the hydraulic relay (C) with a 20mm wrench.

Assembly:

1. Connect the 3 fast connectors (A) to the new hydraulic relay (C) with a 20mm wrench. Make sure to connect each fast connector to its original location.
2. Pass the hydraulic relay (C) thread (e) through the hole (f) of the controller support bracket (D).
3. Gently fasten the brass connector adaptor (B) to the hydraulic relay (C) thread (e) with a 10mm wrench.
4. Connect the control tubes to the 4 fast connectors (A). Make sure to connect each control tube to its original location (see control-tube connection scheme, [page 12](#)).

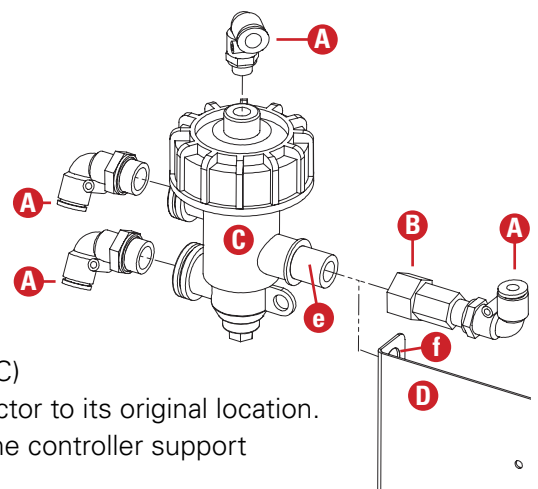

TROUBLESHOOTING

Aquative solenoid replacement

Disassembly:

1. Open the flush controller box using a cross-head screwdriver.
2. Extract one battery to deactivate the controller during the procedure.
3. Take the battery compartment out.
4. Disconnect the solenoid wires from the terminal block.
5. Loosen the cable gland nut by hand.
6. Gently pull the solenoid wires through the cable gland.
7. Disconnect the control tubes from the 3 fast connectors (A).
8. Manually unscrew 2 screws (B) with a crosshead screwdriver.
9. Release the Aquative solenoid (C) from the Controller Support Bracket (D).
10. Disconnect the 3 fast connectors (A) from the Aquative solenoid (C) with a 14mm wrench.

Assembly:

1. Connect the 3 fast connectors (A) to the new Aquative solenoid (C) with a 14mm wrench.
2. Place the Aquative solenoid (C) on Controller Support Bracket (D).
3. Manually fasten 2 screws (B) with a crosshead screwdriver.
4. Gently thread the solenoid wires through the cable gland.
5. Connect the solenoid wires to the terminal block (mind polarity).
6. Refasten the cable gland nut by hand.
7. Connect the control tubes to the 3 fast connectors (A). (Mind proper location, see control-tube connection scheme, [page 12.](#))
8. Put the battery compartment back in place (make sure that the solenoid wires pass under the battery compartment in a tidy manner).
9. Put the extracted battery back in place to reactivate the controller.
10. Close the flush controller box (mind the alignment of the cover gasket to ensure sealing).

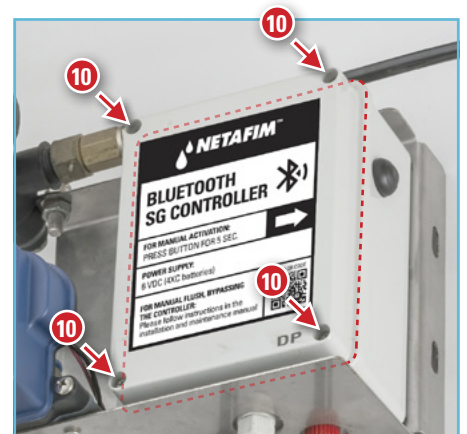
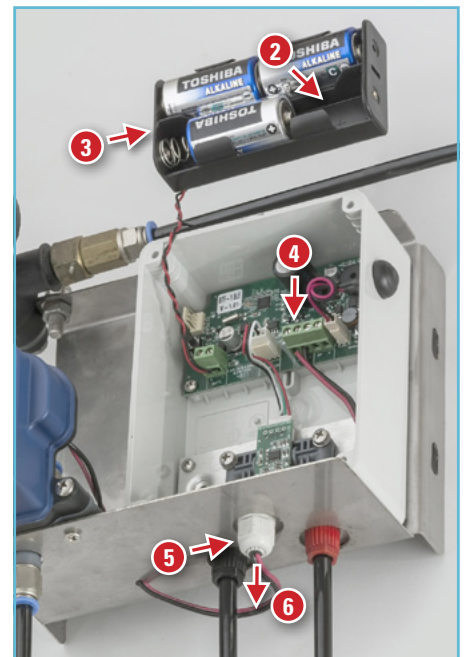
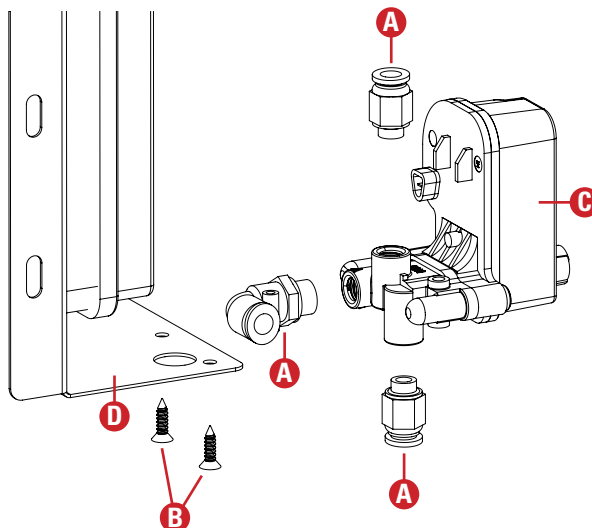

If your SG filter is equipped with the Filtron 1-10 flush controller, see its User Manual enclosed with it.

TROUBLESHOOTING

PD sensor unit replacement

1. Open the flush controller box using a cross-head screwdriver.

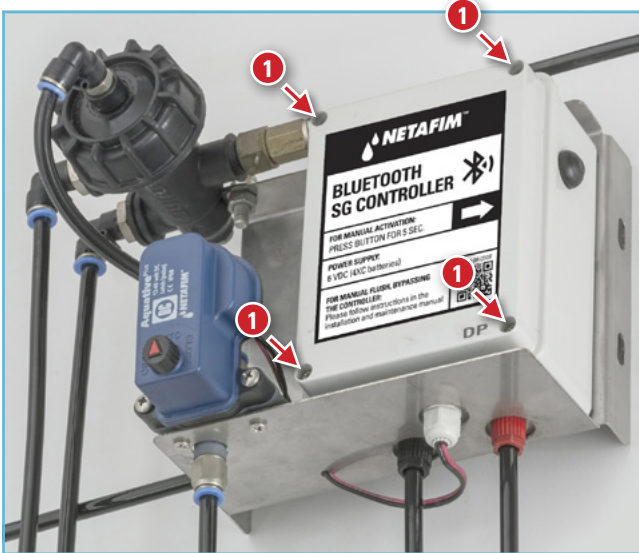

2. Extract one battery to deactivate the controller during the procedure.
3. Take the battery compartment out to allow access to the PD sensor unit.
4. Disconnect the PD sensor from the terminal block.
5. Release the 2 control tube nuts by hand.

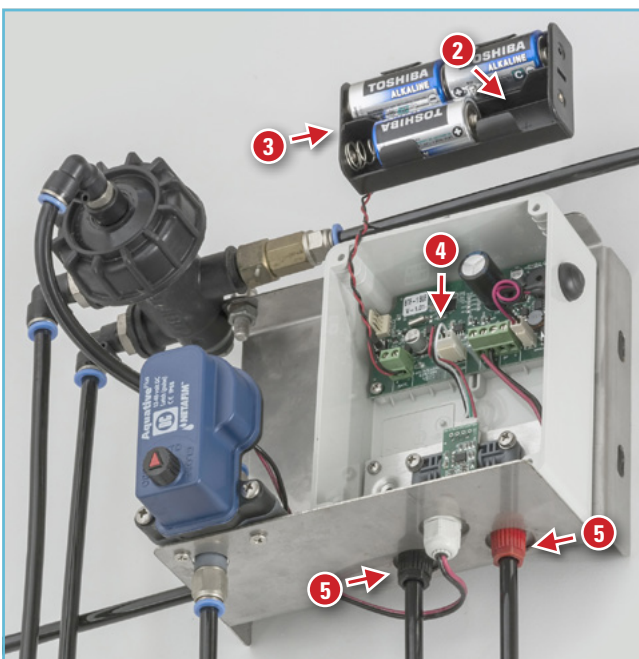

6. Disconnect the 2 control tubes.

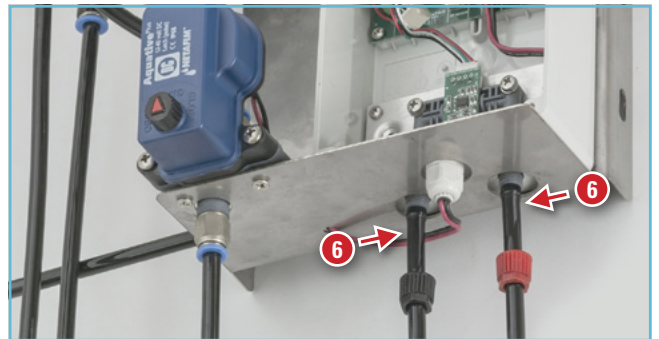

7. Release the PD sensor unit 2 screws using a cross-head screwdriver (mind the washers).
8. Remove the PD sensor.

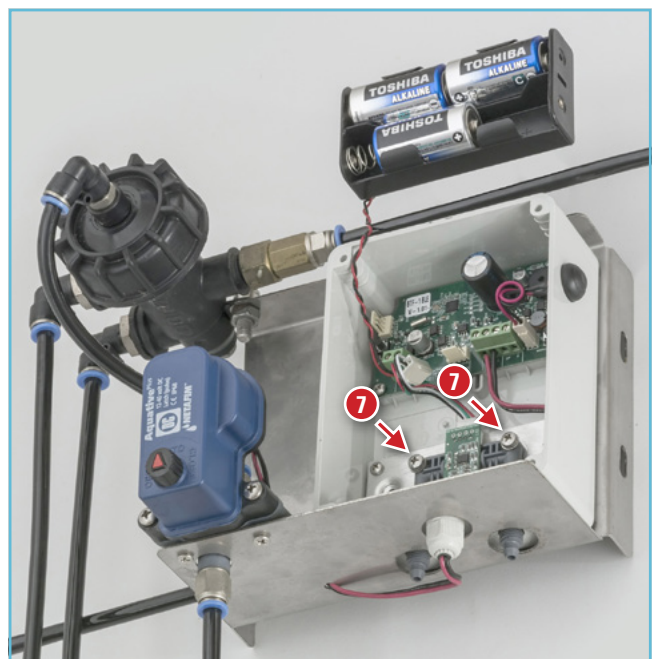

Continued on the next page

If your SG filter is equipped with the Filtron 1-10 flush controller, see its User Manual enclosed with it.

TROUBLESHOOTING

Replacing the analog PD sensor unit (cont'd)

9. Put the new PD sensor unit in place.

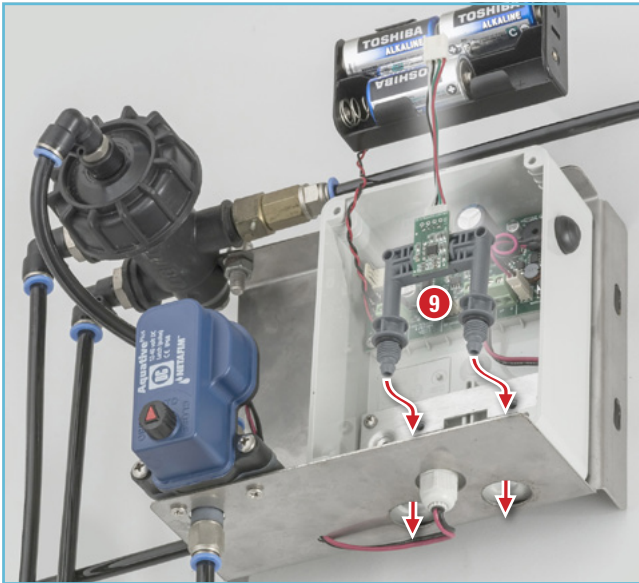

10. Refasten the PD sensor unit 2 screws (mind the washers).

11. Connect the PD sensor to the terminal block.

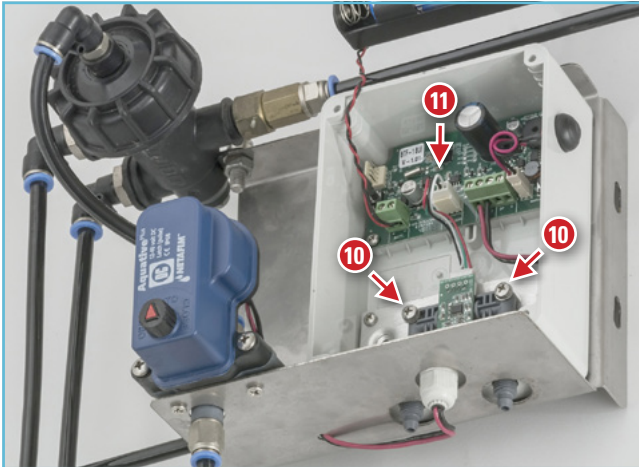

12. Reconnect the 2 control tubes:
Left = low pressure (black nut),
Right = high pressure (red nut).

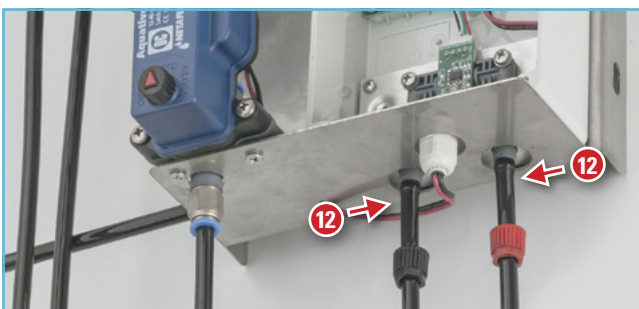

13. Refasten the 2 control tube nuts by hand.

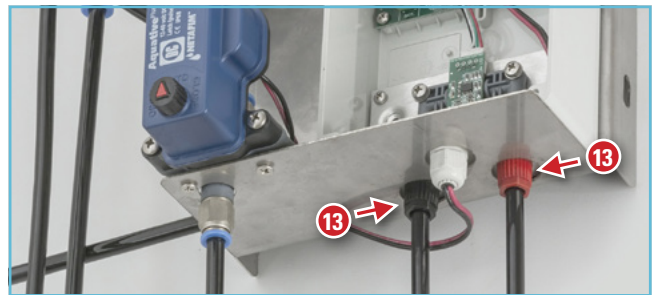

14. Put the battery compartment back in place.

15. Put the extracted battery back in place to reactivate the controller.

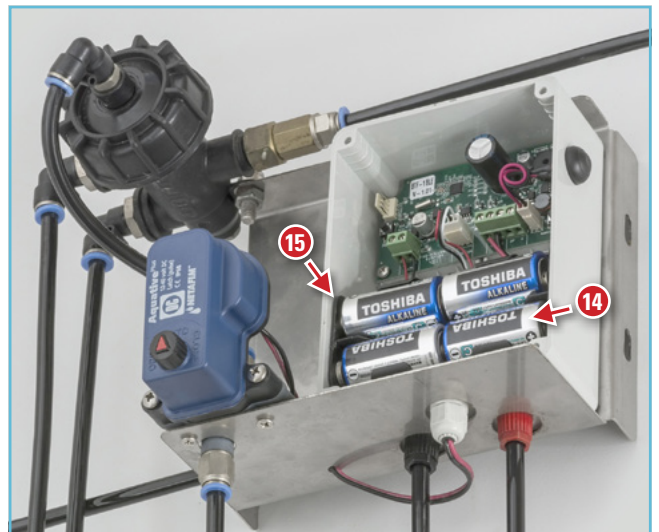

16. Close the flush controller box (mind the alignment of the cover gasket to ensure sealing).

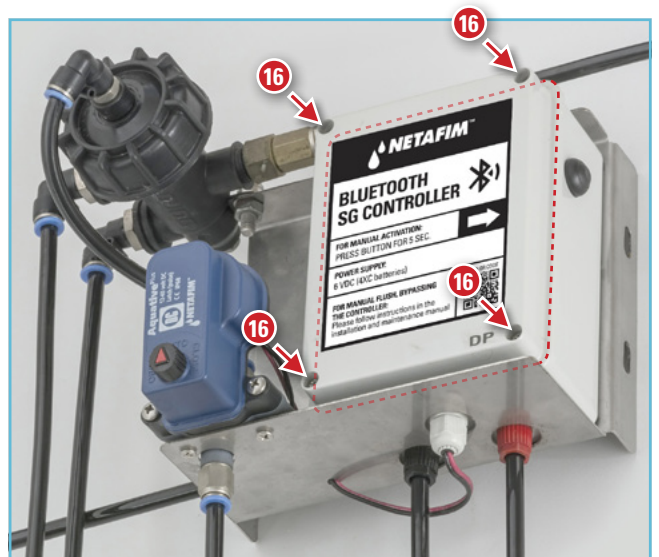

REPLACEMENT PARTS

Filters

SG A H 4" 5300 DC

Filtration grade (micron)	Cat. No.		
	ANSI	BSTD	DIN
100 µm	71960-000252	71960-000269	71960-000272
130 µm	71960-000253	71960-000270	71960-000273
200 µm	71960-000254	71960-000271	71960-000274
300 µm	Upon request	Upon request	Upon request
500 µm	Upon request	Upon request	Upon request



NOTE

- All filter models are available with 100, 130, 200, 300 or 500 micron (150, 115, 80, 50 or 35 mesh) filtration grade. (Other filtration grades are available upon request).
- All filters with DC controller and DC solenoid.

SG A H 4" S 7900 DC

Filtration grade (micron)	Cat. No.		
	ANSI	BSTD	DIN
100 µm	71960-000275	71960-000299	71960-000302
130 µm	71960-000276	71960-000300	71960-000303
200 µm	71960-000277	71960-000301	71960-000304
300 µm	Upon request	Upon request	Upon request
500 µm	Upon request	Upon request	Upon request

SG A H 6" 5300 DC

Filtration grade (micron)	Cat. No.		
	ANSI	BSTD	DIN
100 µm	71960-000305	71960-000319	71960-000322
130 µm	71960-000306	71960-000320	71960-000323
200 µm	71960-000307	71960-000321	71960-000324
300 µm	Upon request	Upon request	Upon request
500 µm	Upon request	Upon request	Upon request

SG A H 6" S 7900 DC

Filtration grade (micron)	Cat. No.		
	ANSI	BSTD	DIN
100 µm	71960-000325	71960-000339	71960-000359
130 µm	71960-000326	71960-000340	71960-000360
200 µm	71960-000327	71960-000341	71960-000361
300 µm	Upon request	Upon request	Upon request
500 µm	Upon request	Upon request	Upon request

SG A H 8" 7900 DC

Filtration grade (micron)	Cat. No.			
	ANSI	BSTD	DIN PN10	DIN PN16
100 µm	71960-000379	71960-000399	71960-000419	71960-000439
130 µm	71960-000380	71960-000400	71960-000420	71960-000440
200 µm	71960-000381	71960-000401	71960-000421	71960-000441
300 µm	Upon request	Upon request	Upon request	Upon request
500 µm	Upon request	Upon request	Upon request	Upon request

SG A H 10" 7900 DC

Filtration grade (micron)	Cat. No.			
	ANSI	BSTD	DIN PN10	DIN PN16
100 µm	71960-000450	71960-000460	71960-000470	71960-000480
130 µm	71960-000451	71960-000461	71960-000471	71960-000481
200 µm	71960-000452	71960-000462	71960-000472	71960-000482
300 µm	Upon request	Upon request	Upon request	Upon request
500 µm	Upon request	Upon request	Upon request	Upon request

REPLACEMENT PARTS

Spare parts

Main parts and assemblies

Part	Description	Cat. No.	Qty.	See details on page:
1	Metal Body		1	39
2	Fine Screen Assembly kit		1	40
3	Flush assembly		1	40
4	Coarse Screen Assembly	71965-000401	1	
5	Piston Cover Assembly	71965-000402	1	42
6	Filter Body Cap	71965-000403	1	
7	Electronic Controller Assembly	71965-000510	1	44
8	Pressure Gauge Assembly	71965-000405	1	45
9	Cover Gasket	71965-000406	2	46 (Seal Kit)
10	O-ring	71965-000407	2	46 (Seal Kit)
11	10mm SS Washer and Nuts - 12 pcs set	71965-000256	2	46 (Washers and Nuts set)
12	SGH PE 1" M Cap	71965-000409	1	
13	Complete O-ring and gasket kit for SG Filters	71965-000450	1	46 (Seal Kit)

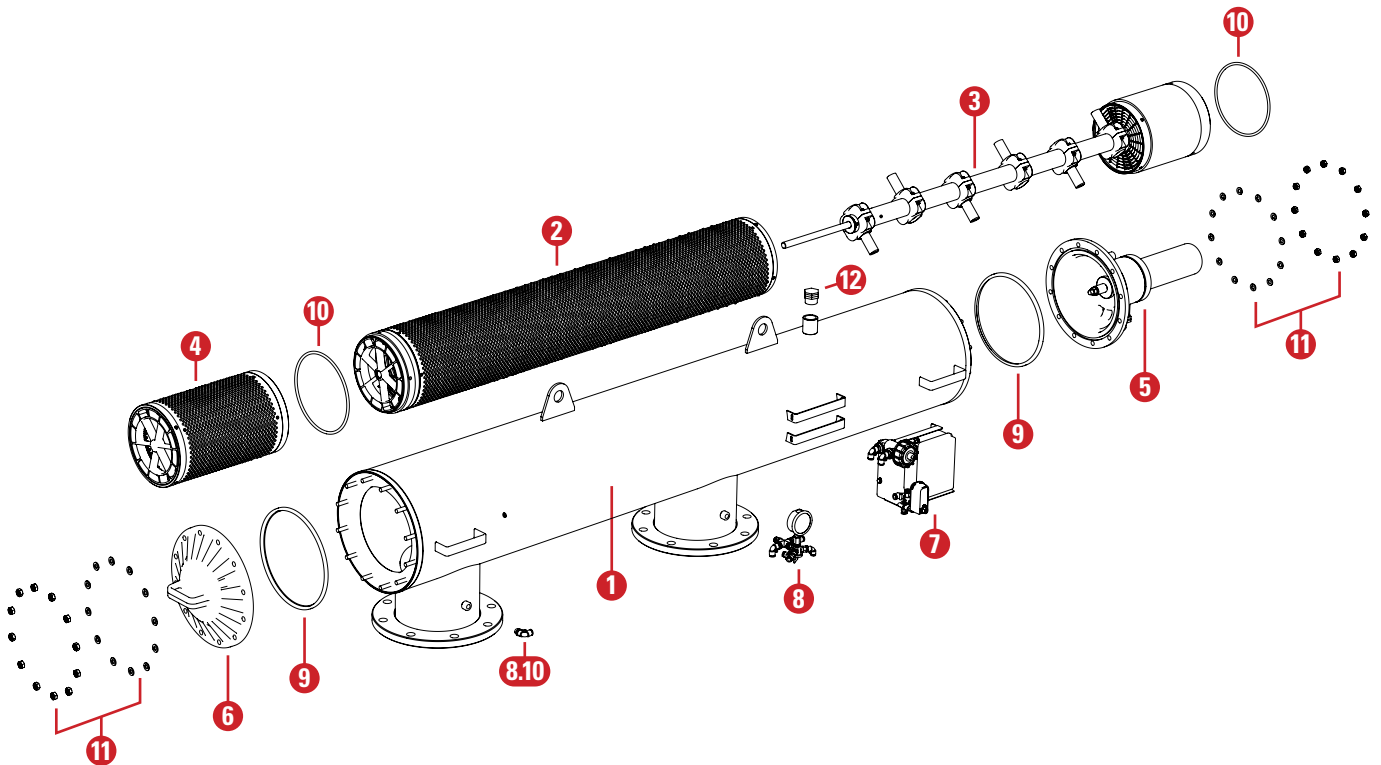

Metal Body

Part	Connection type	Cat. No.						Qty.
		SGH 4"	SGH 4"S	SGH 6"	SGH 6"S	SGH 8"	SGH 10"	
1	DIN	71965-000115	71965-000118	71965-000121	71965-000124	71965-000127	71965-000130	1
	BSTD	71965-000116	71965-000119	71965-000122	71965-000125	71965-000128	71965-000131	1
	ANSI	71965-000117	71965-000120	71965-000123	71965-000126	71965-000129	71965-000132	1

REPLACEMENT PARTS

Fine screen Assembly

Part	Filtration grade (micron)	Cat. No.					Qty.	
		SGH 4"	SGH 6"	SGH 4"S	SGH 6"S	SGH 8"		SGH 10"
2	100 µm	71965-000300					71965-000303	1
	130 µm	71965-000301					71965-000304	1
	200 µm	71965-000302					71965-000305	1

The Fine screen Assembly consists of the following parts

Part	Description	Cat. No.	Qty.
2.1	Fine Screen 100/130/200µm		1
2.2	Centring Ring with Bearing	71965-000267	1
2.3	O-ring (See Seal Kit , page 46)		1
2.4	Countersunk Flat Head Cross Recess Screw 4x16H A2x70		4

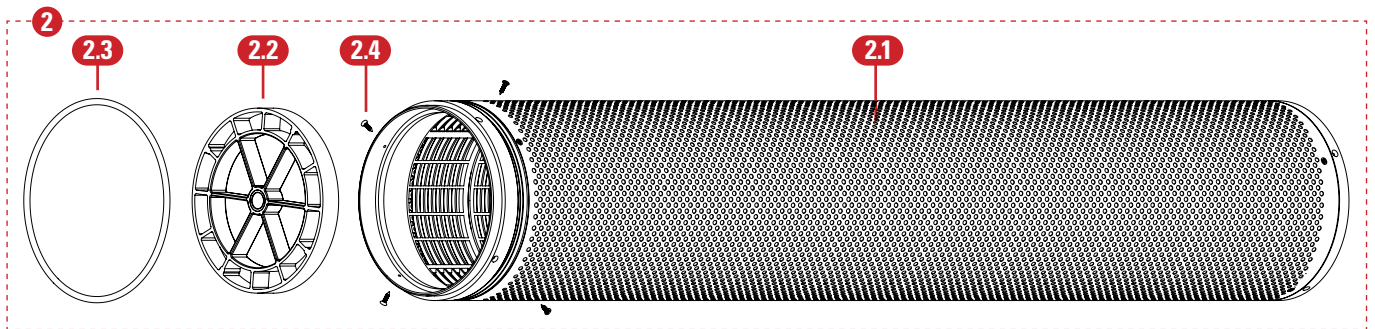

Flush Assembly

Part	Description	Cat. No.					Qty.	
		SGH 4"	SGH 6"	SGH 4"S	SGH 6"S	SGH 8"		SGH 10"
3	Flush Assembly	71965-000400					71965-000415	1

The Flush Assembly consists of the following parts

Part	Description	Qty.
3.1	Turbine Chamber Main Body PVC	1
3.2	O-ring (See Seal Kit , page 46)	1
3.3	Suction Assembly Without Housing (See page 41)	1

REPLACEMENT PARTS

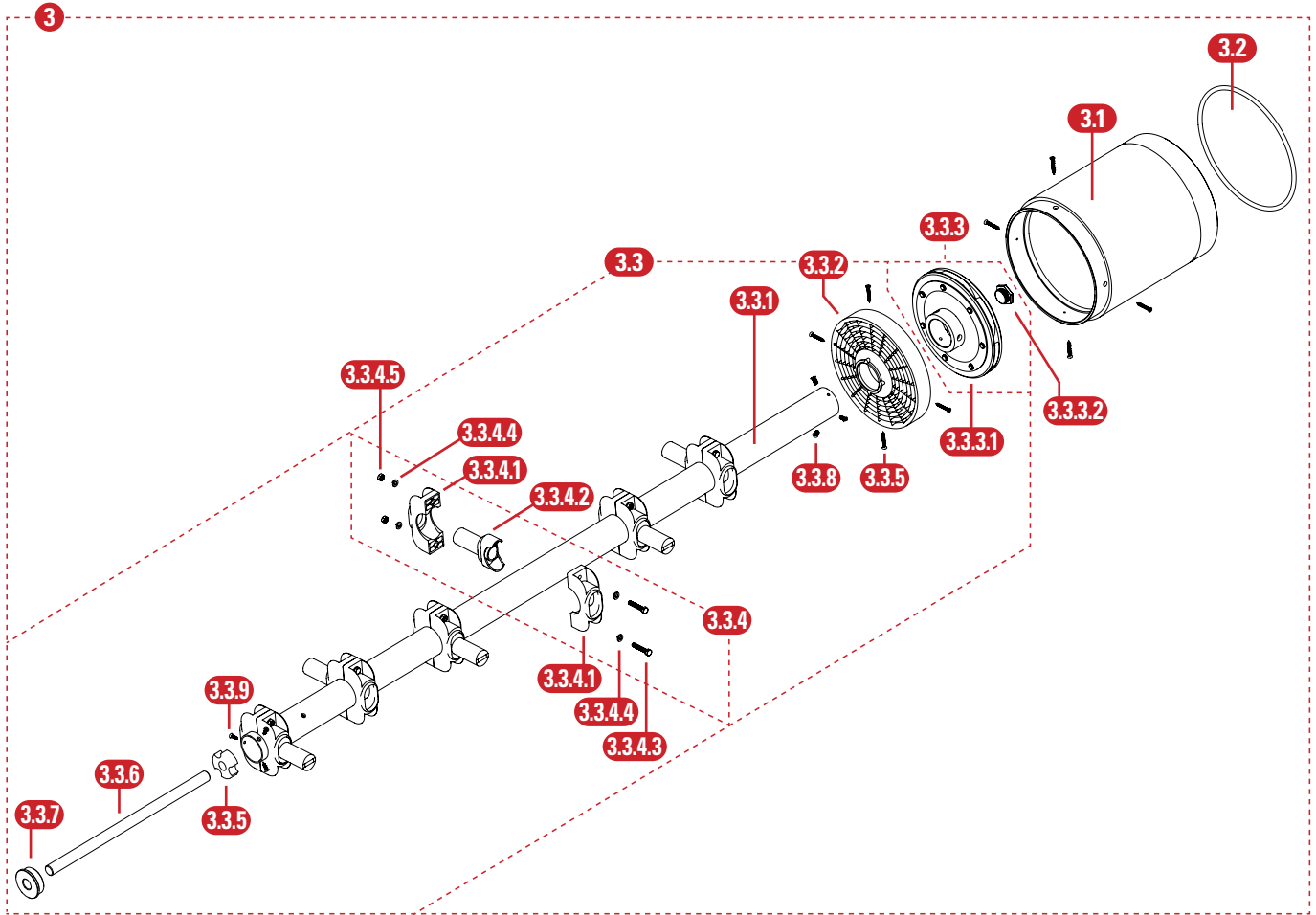

Suction Assembly Without Housing

Part	Description	Cat. No.						Qty.
		SGH 4"	SGH 6"	SGH 4"S	SGH 6"S	SGH 8"	SGH 10"	
3.3	Suction Assembly Without Housing	71965-000410			71965-000416			1

The Suction Assembly consists of the following parts

Part	Description	Cat. No.	Qty.
3.3.1	Suction Assembly Center Pipe		1
3.3.2	Turbine Chamber Partition		1
3.3.3	Turbine Assembly	71965-000411	1
3.3.4	Nozzle Assembly	71965-000412	4
3.3.5	Center Pipe Shaft Connecting Plastic Bolt		1
3.3.6	Center Pipe Shaft		1
3.3.7	Center Pipe Top Plug		1
3.3.8	Countersunk Flat Head Cross Recess Screw 5x12H A2x70		3
3.3.9	Countersunk Flat Head Cross Recess Screw 4.2x16H A2x70		6

REPLACEMENT PARTS

Turbine Assembly

Part	Description	Cat. No.	Qty.
3.3.3	Turbine Assembly	71965-000411	1

The Turbine Assembly consists of the following parts

Part	Description	Cat. No.	Qty.
3.3.3.1	Turbine Set		1
3.3.3.2	Turbine Brass Bearing	71965-000266	1

Nozzle Assembly

Part	Description	Cat. No.	Qty.
3.3.4	Nozzle Assembly	71965-000412	1

The Nozzle Assembly consists of the following parts

Part	Description	Qty.
3.3.4.1	Nozzle Clamp	2
3.3.4.2	Nozzle Round	1
3.3.4.3	M6x35 HEX Screw A2x70	2
3.3.4.4	M6 Washer A2x70	4
3.3.4.5	M6 Hex Nut A2x70	2

Piston Cover Assembly

Part	Description	Cat. No.	Qty.
5	Piston Cover Assembly Stroke 200mm	71965-000402	1

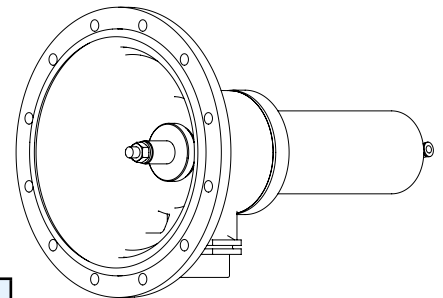

The Piston Cover Assembly consists of the following parts

Part	Description	Cat. No.	Qty.
5.1	Piston Cover		1
5.2	Piston Cylinder S200 + Plug (See below)	71965-000600	1
5.3	Cylinder Gasket (See Seal Kit , page 46)		1
5.4	Rod Assembly (See below)	71965-000413	1
5.5	Cover Gasket NBR (See Seal Kit , page 46)		1
5.6	M6 Bolts and Washers Kit (See below)	71965-000260	1
5.7	Plastic Nipple 2" BSP		1

REPLACEMENT PARTS

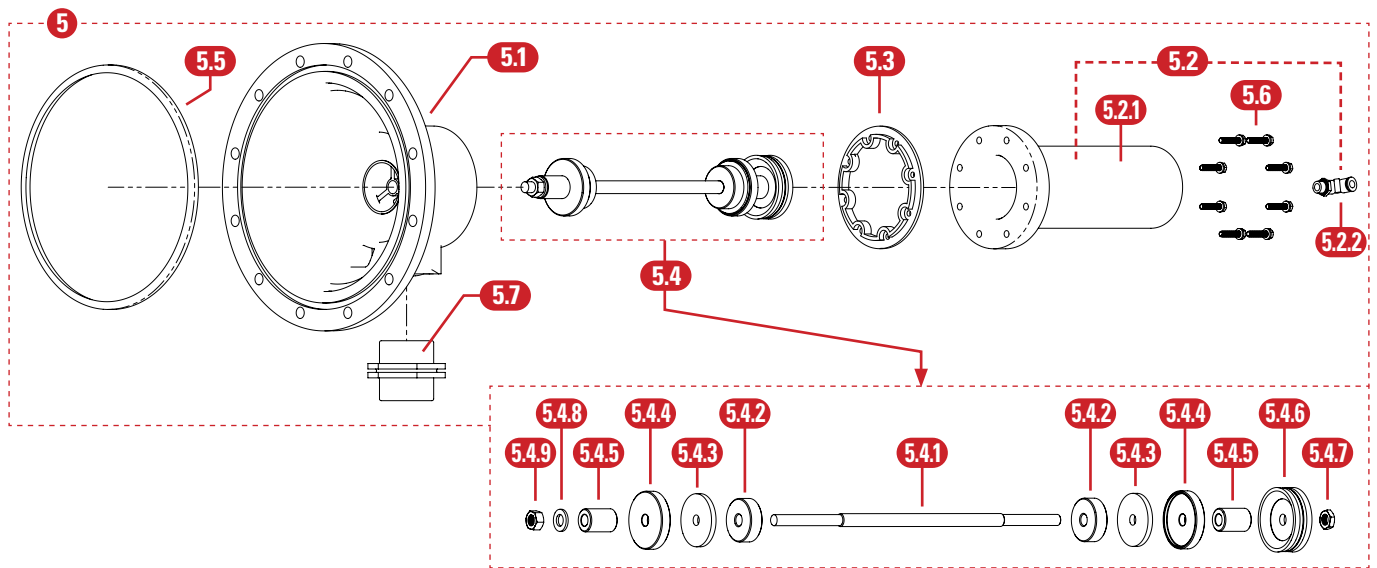

Piston Cylinder S200 + Plug Assembly

Part	Description	Cat. No.	Qty.
5.2	Piston Cylinder S200 + Plug Assembly	71965-000600	1

The Piston Cylinder S200 + Plug Assembly consists of the following parts

Part	Description	Qty.
5.2.1	Piston Cylinder S200	1
5.2.2	Plug in Plastic Connector 90 deg 10mm X 0.250	1

Rod Assembly

Part	Description	Cat. No.	Qty.
5.4	Rod Assembly	71965-000413	1

The Rod Assembly consists of the following parts

Part	Description	Qty.
5.4.1	Rod	1
5.4.2	Plastic Spacer	2
5.4.3	Seal Disc	2
5.4.4	Brass Disk Seat	2
5.4.5	Plastic Disc	2
5.4.6	Piston Seal	1
5.4.7	M12 Half Hex Nut A2x35	1
5.4.8	M12 Plain Washer A2x70	1
5.4.9	M12 Hex Nut A2x70	1

REPLACEMENT PARTS

M6 Bolts and Washer Kit

Part	Description	Cat. No.	Qty.
5.6	M6 Bolts and Washer Kit	71965-000260	1

The Bolts and Washer Kit consists of the following parts

Part	Description	Qty.
5.6.1	M6 Plain Washer A2x70	8
5.6.2	M6x25 Hex Screw A2x70	8

Electronic Controller Assembly*

Part	Description	Cat. No.	Qty.
7	Electronic Controller Assembly	71965-000510	1

The Electronic Controller Assembly consists of the following parts

Part	Description	Cat. No.	Qty.
7.1	Aquative DC Assembly (See page 45)	71965-000261	1
7.2	Electronic Controller Box SG		1
7.3	Controller Support Bracket (See page 44)	71965-000414	1
7.4	Hydraulic Relay Assembly		1

*If your SG filter is equipped with the Filtron 1-10 flush controller, see its User Manual enclosed with it.

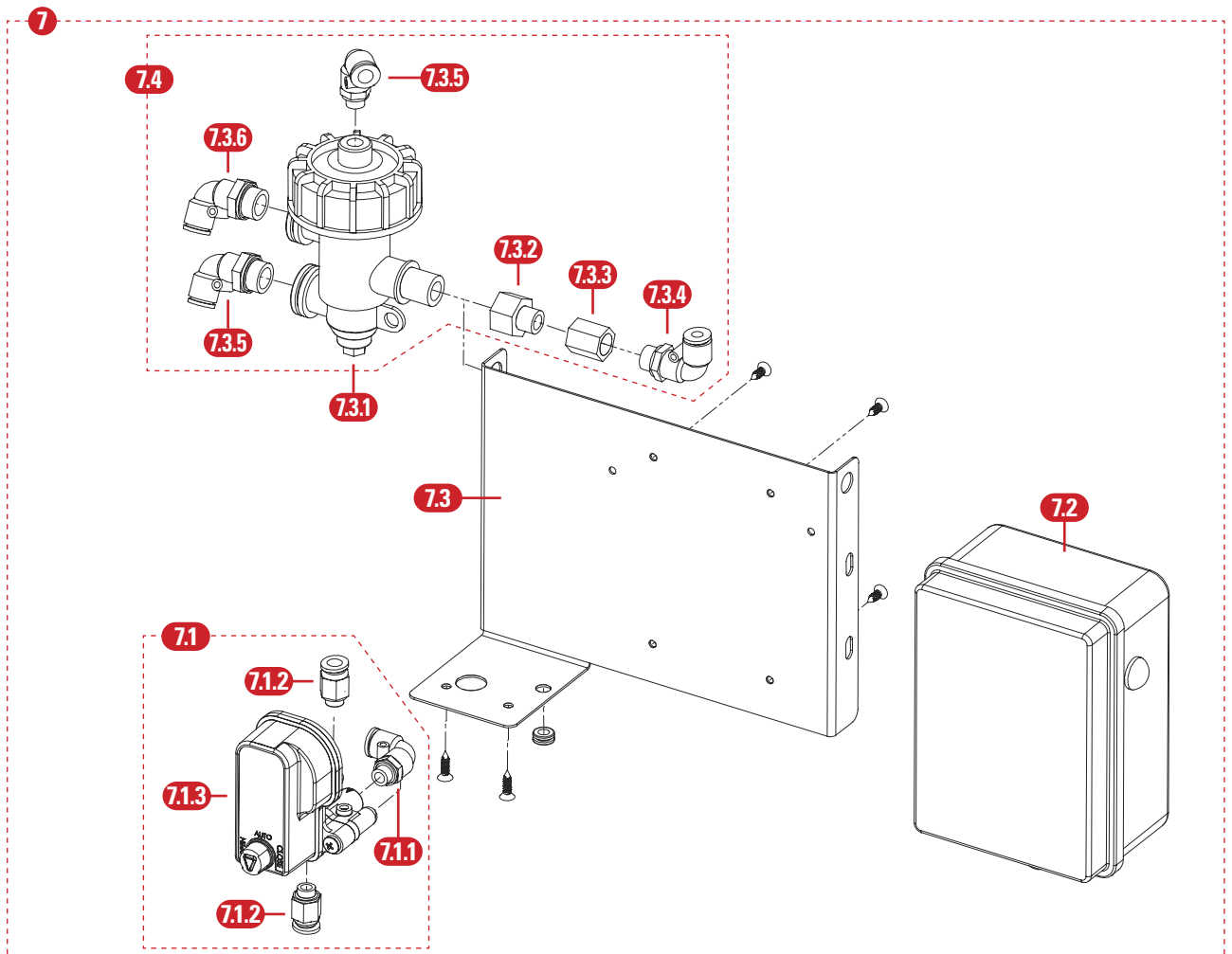

REPLACEMENT PARTS

Aquative DC Assembly

Part	Description	Cat. No.	Qty.
7.1	Aquative DC Assembly	71965-000261	1

The Aquative DC Assembly consists of the following parts

Part	Description	Cat. No.	Qty.
7.1.1	Aquative DC	35500-001905	1
7.1.2	Plug in Metal Connector 8mm X 1/8"		2
7.1.3	Plug in Metal Connector 90 deg 8mm X 1/8"		1

Hydraulic Relay Assembly

Part	Description	Cat. No.	Qty.
7.3	Hydraulic Relay Assembly	71965-000414	1

The Hydraulic Relay Assembly consists of the following parts

Part	Description	Cat. No.	Qty.
7.3.1	SG Hydraulic Relay	71680-000800	1
7.3.2	Brass Connector Adaptor 3/8" X 1/4"		1
7.3.3	Brass Connector 1/4" X 1/4" F-F		1
7.3.4	Plug in Metal Connector 10mm X 1/4"		1
7.3.5	Plug in Metal Connector 90 deg 8mm X 3/8"		1
7.3.6	Plug in Metal Connector 90 deg 10mm X 3/8"		1

Pressure Gauge Assembly

Part	Description	Cat. No.	Qty.
8	Pressure Gauge Assembly	71965-000405	1 set

The Pressure Gauge Assembly consists of the following parts

Part	Description	Cat. No.	Qty.
8.1	Three Way Valve 3 x 1/8"		1
8.2	Plug in Plastic Connector 90 deg 8mm X 1/8"		3
8.3	Plug in Plastic Double Connector 8 mm X 1/4"		1
8.4	Pressure Gauge 10Bar 1/4" BSP	77456-000153	1
8.5	Brass Connector Adaptor 1/4" X 1/8" M-M		1
8.6	Brass Connector Cross 1/4"		1
8.7	Brass Connector 1/4" X 1/4" M-M		1
8.8	Plug in Plastic Connector Side Leg 8mm X 1/8"		1
8.9	Brass Connector 1/4" X 1/4" F-F		1
8.10	Plug in Plastic connector 90 deg 10 mm X 1/4"		1
8.11	Plug in Plastic connector 90 deg 8 mm X 1/4"		1

REPLACEMENT PARTS

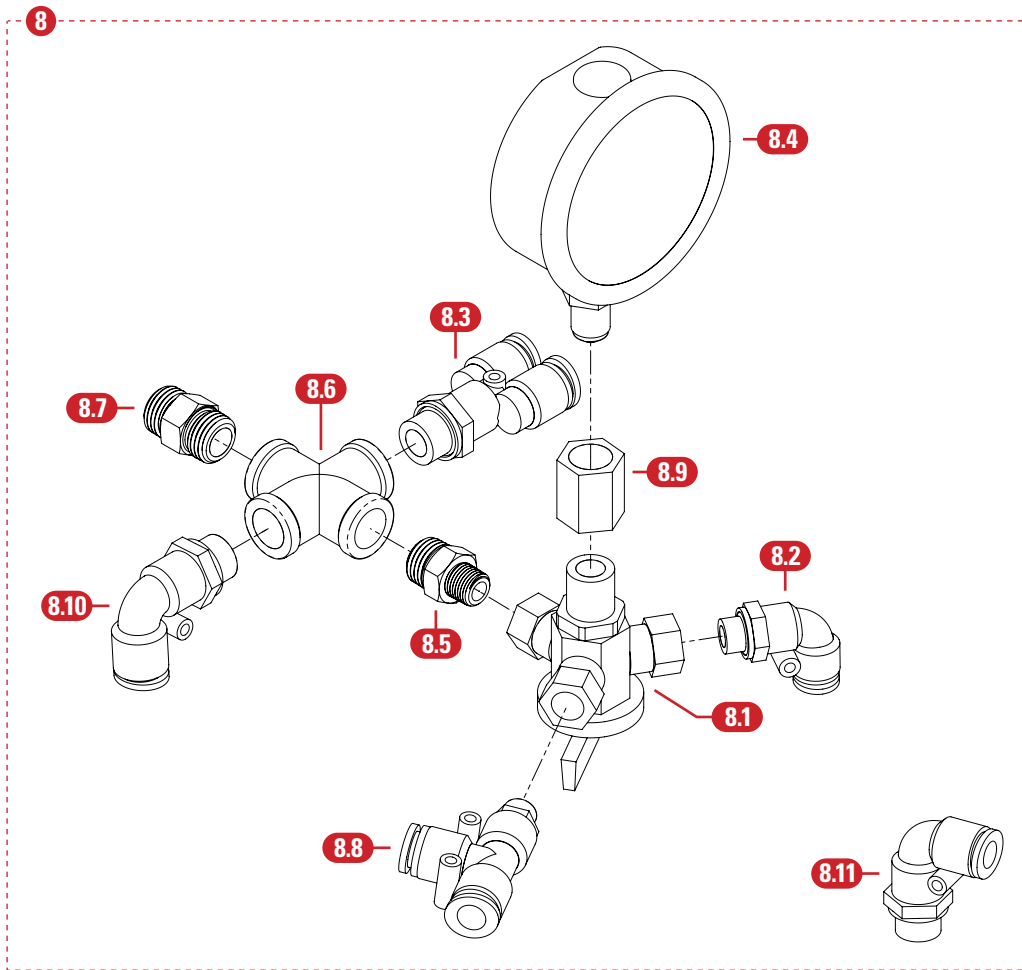

Washers and Nuts set

Part	Description	Cat. No.	Qty.
11	10mm SS Washer and Nuts, 12 pcs	71965-000256	1

The Washers and Nuts set consists of the following parts

Part	Description	Qty.
11.1	M10 Plain Washer A2x70	12
11.2	M10 Hex Nut A2x70	12

Seal Kit

Part	Description	Cat. No.	Qty.
13	Complete O-ring and gasket kit for SG filters	71965-000450	1

The Seal Kit consists of the following parts

Part	Description	Qty.
13.1	Cover Gasket	2
13.2	O-ring	2

WARRANTY

Netafim™ warrants the ScreenGuard™ screen filter metal body to be free of corrosion, defects in material and workmanship for 5 (five) years from the date of installation.

Netafim™ warrants the ScreenGuard™ screen filter Piston Assembly and Cover in case of fracture under normal conditions of use, and to be free of defects in material and workmanship and for 5 (five) years from the date of installation.

Netafim™ warrants the ScreenGuard™ screen filter bearings, O-rings and seals for 2 (two) years from the date of installation, under normal conditions of use.

Netafim™ warrants the ScreenGuard™ screen filter consumable components, the SG! controller, the Aquative solenoid and the SG accelerator for 1 (one) years from the date of installation.

If a defect is discovered during the applicable warranty period, Netafim™ will repair or replace, at its discretion, the product or the defective part.

This warranty does not extend to repairs, adjustments or replacements of a Netafim™ screen filter system or part that results from reasonable wear and tear, misuse, negligence, alteration, force majeure, lightning, power surge, improper installation or improper maintenance.

If a defect arises in your Netafim™ product during the warranty period, contact your local Netafim™ representative.

Limited warranty

This warranty is subject to the conditions in Netafim's official warranty statement.

(For the full text of Netafim's official warranty statement, please contact your local Netafim™ representative).

GROW MORE WITH LESS

WWW.NETAFIM.COM